

Safety Switches

Tongue Switches

Trojan™ 5 & 6

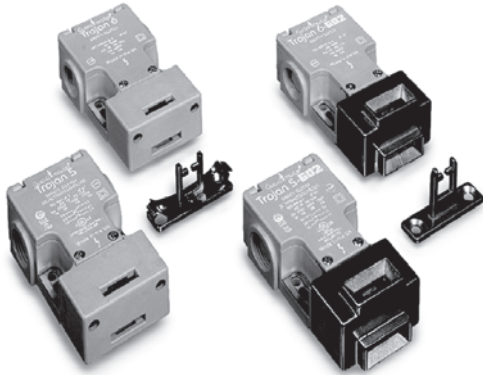

Description

The Trojan family is a universal tongue-operated (or key-operated) safety-interlock switch designed to fit at the leading edge of sliding, hinged or lift-off guards. The dual key entry slots and rotatable head, movable only by releasing the cover screws, allow four actuator entry options. The Trojan contains all of the safety related functions—i.e., forced guided contacts, tamper resistant mechanism—allowing the machine to be safeguarded in compliance with the machine directive.

Operation of the switch is achieved through the insertion of a specially-profiled stainless-steel key that is permanently mounted to the leading edge of the guard door. The standard (not GD2) Trojan actuator includes a self-ejecting mechanism that prevents operation of the switch if the actuator is not mounted to the guard door (e.g., if the operator uses a spare key).

Features

- Strong and versatile, can be used in most applications
- Self-ejecting tamper resistant actuator, only operates when mounted to the guard (not with GD2 models)
- Four possible actuator entry points, easy to install
- GD2 style available for demanding applications

Specifications

Safety Ratings	
Standards	EN 954-1, ISO 13849-1, IEC/EN 60204-1, NFPA 79, EN 1088, ISO 14119, IEC/EN 60947-5-1, ANSI B11.19, AS 4024.1
Safety Classification	Cat. 1 device per EN 954-1 dual channel interlocks suitable for Cat. 3 or 4 systems
Functional Safety Data *	B10d: > 2 x 10 ⁶ operations at min. load PFH _D : > 3 x 10 ⁻⁷ MTTFd: > 385 years Dual channel interlock may be suitable for performance levels Pl _e or Pl _d (according to ISO 13849-1:2006) and for use in SIL2 or SIL3 systems (according to IEC 62061) depending on application characteristics
Certifications	CE Marked for all applicable directives, cULus, TÜV, and CCC

Outputs

Safety Contacts * Direct Opening Action	3 N.C.	2 N.C.	2 N.C.
Auxiliary Contacts	1 N.O.	2 N.O.	1 N.O.
Thermal Current/ <i>I_{th}</i>	10 A		
Rated Insulation Voltage	(U _i) 500V		
Switching Current @ Voltage, Min.	5 mA @ 5V DC		

Utilization Category

Trojan 5 A300/AC-15					
	(U _e)	240V	120V		
	(I _e)	3 A	6 A		
DC-13					
	(U _e)	24V	24V		
	(I _e)	2 A			
Trojan 6 A600/AC-15					
	(U _e)	600V	500V	240V	120V
	(I _e)	1.2 A	1.4 A	3 A	6 A
DC-13					
	(U _e)	24V			
	(I _e)	2 A			

Operating Characteristics

Break Contact Force, Min.	Trojan 5: 12 N (2.7 lbf) & 30 N (6.75 lbf) Trojan 6: 20 N (4.5 lbf)
Actuation Speed, Max.	160 mm (6.29 in.)/s
Actuation Frequency, Max.	2 cycles/s
Operating Radius, Min	175 mm (6.89 in.) [60 mm (2.36 in.) with flexible actuator]
Operating Life @ 100 mA load	1 x 10 ⁶ operations

Environmental

Enclosure Type Rating	IP67
Operating Temperature [C (F)]	-20...+80° (-4...+176°)

Physical Characteristics

Housing Material	UL Approved glass-filled PBT
Actuator Material	Stainless Steel
Weight [g (lb)]	160 (0.35)
Color	Red

* Usable for ISO 13849-1:2006 and IEC 62061. Data other than B10d is based on:

- Usage rate of 1op/10 mins., 24 hrs/day, 360 days/year, representing 51840 operations per year
- Mission time/Proof test interval of 38 years

* The safety contacts are described as normally closed (N.C.) i.e., with the guard closed, actuator in place (where relevant) and the machine able to be started.

Product Selection

Type	Contact			Actuator Type	Cat. No.			
	Safety	Auxiliary	Action		M20 Conduit		Connector§	
					M20	1/2 inch NPT Adaptor	Connect to Distribution Box 6-Pin Micro (M12)	Connect to ArmorBlock Guard I/O 5-Pin Micro (M12)*
Trojan 5 Standard	2 N.C.	1 N.O.	BBM	Standard	440K-T11090	440K-T11202	440K-T11205	—
				Guide/Semi-Flex	440K-T11110	440K-T11203	440K-T11206	—
				Guide/Fully-Flex	440K-T11467	440K-T11204	440K-T11207	440K-T2NNBPS
				—	440K-T11089	—	440K-T11129	—
			BBM Gold Contacts	Standard	440K-T11085	—	—	—
				MBB	Standard	440K-T11118	440K-T11208	440K-T11224
			Guide/Semi-Flex		440K-T11123	440K-T11209	440K-T11363	—
			Guide/Fully-Flex		440K-T11468	440K-T11210	440K-T11364	—
—	440K-T11146	440K-T11469	440K-T11365		—			
Trojan 5 GD2	2 N.C.	1 N.O.	BBM	GD2 Standard	440K-T11336	440K-T11211	440K-T11366	440K-T2NNGPS-NG
				Guide/Semi-Flex	440K-T11337	440K-T11212	440K-T11367	—
				Guide/Fully-Flex	440K-T11338	440K-T11213	440K-T11368	—
				—	440K-T11147	—	440K-T11226	—
			MBB	GD2 Standard	440K-T11339	440K-T11470	440K-T11369	—
				Guide/Semi-Flex	440K-T11340	440K-T11471	440K-T11370	—
				Guide/Fully-Flex	440K-T11341	440K-T11472	440K-T11371	—
				—	440K-T11167	—	440K-T11372	—
Trojan 5 30 N			BBM	Standard	440K-T11333	440K-T91024	440K-T11492	—

§ For connector ratings see page 3-9.

§ With a 5-pin micro (M12) connector, not all contacts are connected. See *Typical Wiring Diagram* on page 3-27 for wiring details.

Type	Contact			Actuator Type	Cat. No.		
	Safety	Auxiliary	Action		M20 Conduit		Connector§
					M20	1/2 inch NPT Adaptor	8-Pin Micro (M12)*
Trojan 6	3 N.C.	1 N.O.	BBM	Standard	440K-T11171	440K-T11435	—
				—	440K-T11449	440K-T11408	—
	2 N.C.	2 N.O.	BBM	Standard	440K-T11174	440K-T11438	—
				—	440K-T11452	440K-T11416	440K-W21BNPH
Trojan 6 GD2	3 N.C.	1 N.O.	BBM	GD2 Standard	440K-T11418	440K-T11466	—
				—	440K-T11188	440K-T11444	—
			MBB	—	440K-T11456	440K-T11457	—
	2 N.C.	2 N.O.	BBM	GD2 Standard	440K-T11445	440K-T11425	—
				—	440K-T11459	440K-T11433	440K-W21BNPH-NG
				MBB	—	440K-T11460	440K-T11461

§ For connector ratings see page 3-9.

§ With an 8-pin micro (M12) connector, not all contacts are connected. See *Typical Wiring Diagram* on page 3-27 for wiring details.

Safety Switches

Tongue Switches

Trojan™ 5 & 6

Recommended Logic Interfaces

Description	Safety Outputs	Auxiliary Outputs	Terminals	Reset Type	Power Supply	Cat. Page No.	Cat. No.
Single-Function Safety Relays							
MSR127RP	3 N.O.	1 N.C.	Removable (Screw)	Monitored Manual	24V AC/DC	5-24	440R-N23135
MSR127TP	3 N.O.	1 N.C.	Removable (Screw)	Auto./Manual	24V AC/DC	5-24	440R-N23132
MSR126T	2 N.O.	None	Fixed	Auto./Manual	24V AC/DC	5-22	440R-N23117
MSR30RT	2 N.O. Solid State	1 N.O. Solid State	Removable	Auto./Manual or Monitored Manual	24V DC	5-16	440R-N23198
Modular Safety Relays							
MSR210P Base 2 N.C. only	2 N.O.	1 N.C. and 2 PNP Solid State	Removable	Auto./Manual or Monitored Manual	24V DC from the base unit	5-74	440R-H23176
MSR220P Input Module	—	—	Removable	—	24V DC	5-78	440R-H23178
MSR310P Base	MSR300 Series Output Modules	3 PNP Solid State	Removable	Auto./Manual Monitored Manual	24V DC	5-94	440R-W23219
MSR320P Input Module	—	2 PNP Solid State	Removable	—	24V DC from the base unit	5-98	440R-W23218

Note: For additional Safety Relays connectivity, see the Safety Relays section (page 5-8) of this catalog.

For additional Safety I/O and Safety PLC connectivity, see the Programmable Safety System section (page 5-107) of this catalog.

For application and wiring diagrams, see the Safety Applications section (page 10-1) of this catalog.

Connection Systems

Description	Trojan 5		Trojan 6
	5-Pin Micro (M12)	6-Pin Micro (M12)	8-Pin Micro (M12)
Cordset	—	889R-F6ECA-*	889D-F8AB-*
Patchcord	889R-F5ECRM-*	889R-F6ECRM-⊛	889D-F8ABDM-⊛
Distribution Box	—	898R-F68MT-A5	—
Shorting Plug	—	898R-P61MU-RM	—
T-Port	—	—	—









* Replace symbol with 2 (2 m), 5 (5 m), or 10 (10 m) for standard cable lengths.

⊛ Replace symbol with 1 (1 m), 2 (2 m), 3 (3 m), 5 (5 m), or 10 (10 m) for standard cable lengths.

‡ Replace symbol with 4 or 8 for number of ports.

Note: For additional information, see the Safety Connection System section (page 7-1) of this catalog.

Accessories

Description	To Be Used With:	Dimensions	Cat. No.
 Standard actuator	Trojan T5 and T6 Standard Models Only	3-51	440K-A11095
 GD2 standard actuator	GD2 Models Only	3-50	440G-A27011
 GD2 flat actuator	GD2 Models Only	3-51	440K-A11112
 Alignment guide with semi-flexible actuator	Discard Alignment Guide for GD2 Models	3-51	440K-A11144
 Alignment guide with fully-flexible actuator	Discard Alignment Guide for GD2 Models	3-52	440K-A27010
 Sliding bolt actuator	GD2 Models Only	3-55	440G-A27163
 Catch and Retainer Kit	Trojan T5 and T6 Standard Models Only	3-50	440K-A11094
	Trojan T5 Standard Models Only	—	440A-A11495
	Trojan T5 GD2		440A-A11496
	Trojan T6 Standard Models Only		440A-A11497
	Trojan T6 GD2		440A-A11498
 Dust Cover	All Models	—	440K-A17180

3-Interlock
Switches

Safety Switches

Tongue Switches

Trojan™ 5 & 6

Approximate Dimensions

Dimensions are shown in mm (in.). Dimensions are not intended to be used for installation purposes.

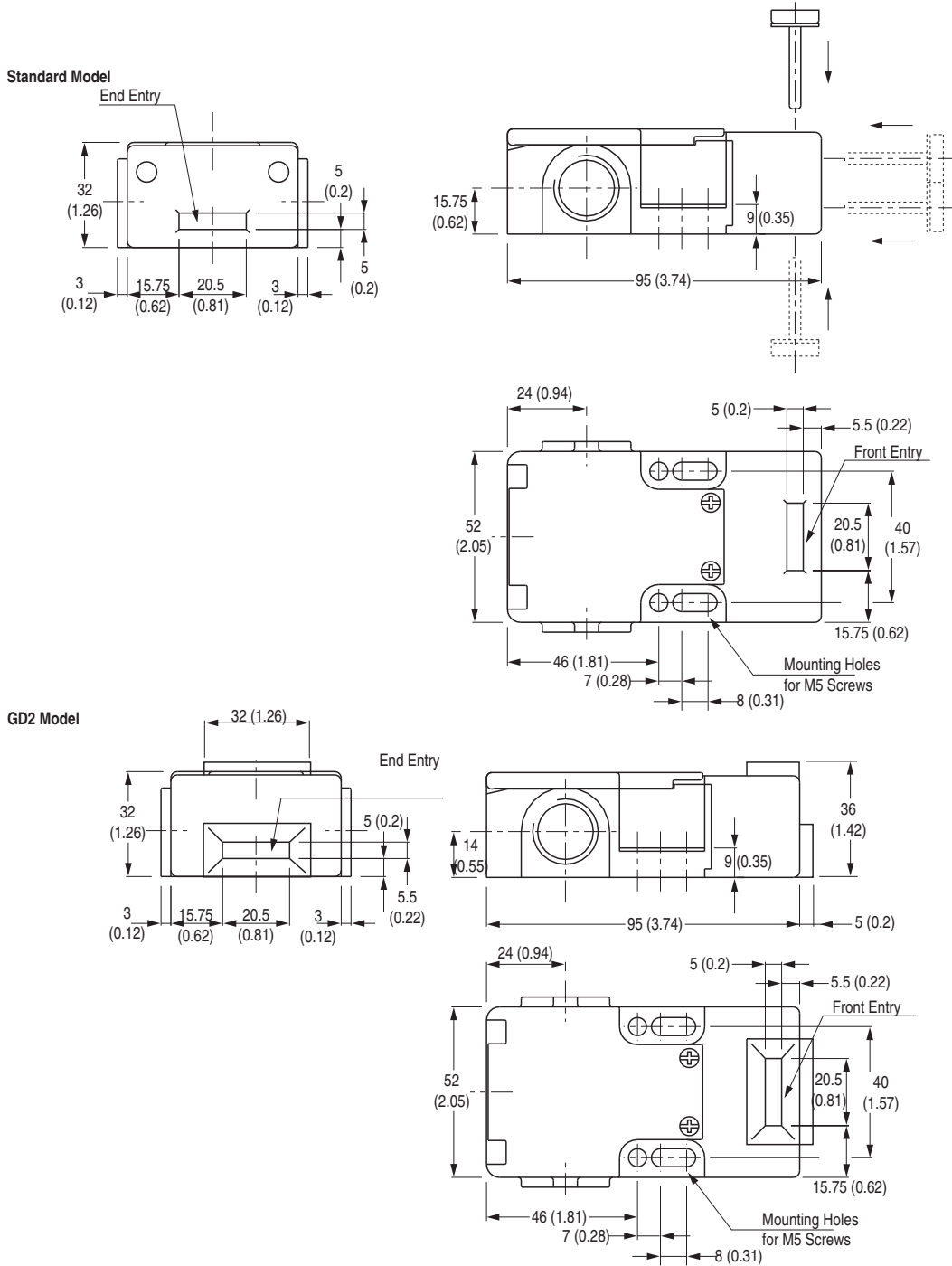

Note: 2D, 3D and electrical drawings are available on www.ab.com.

3-Interlock Switches

Typical Wiring Diagrams

Description	Trojan 5		Trojan 6	
	2 N.C. & 1 N.O.		2 N.C. & 2 N.O.	
Contact Configuration				
Contact Action				
6-Pin Micro (M12)			—	
5-Pin Micro (M12) for ArmorBlock Guard I/O			—	
8-Pin Micro (M12)	—			
6-Pin Cordset 889R-F6ECA-*	Red/White	Safety A	—	
	Red/Black		—	
	Red	Safety B	—	
	Red/Blue		—	
	Green	Aux	—	
Red/Yellow	—			
8-Pin Cordset 889D-F8AB-*	Grey	—	Safety A	—
	Red	—	Safety B	—
	Yellow	—	Aux A	—
	Pink	—	NA	—







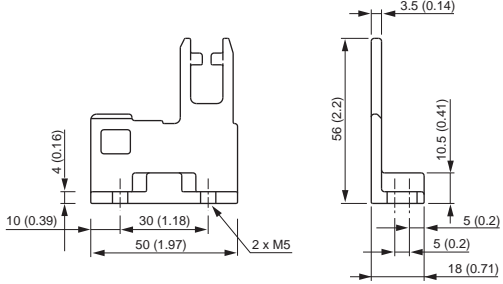

* Replace symbol with 2 (2 m), 5 (5 m) or 10 (10 m) for standard cable lengths.

3-Interlock Switches

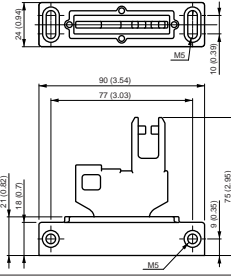
Safety Switches
Accessories
Actuators

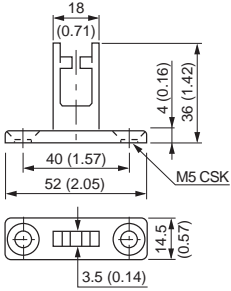
Accessories for Interlock and Guard Locking Switches

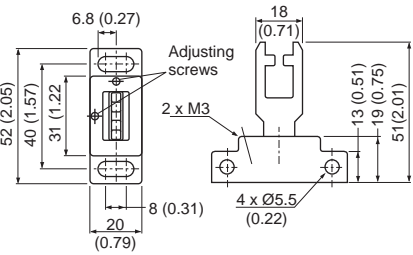

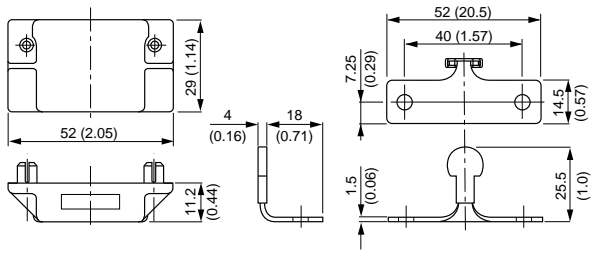





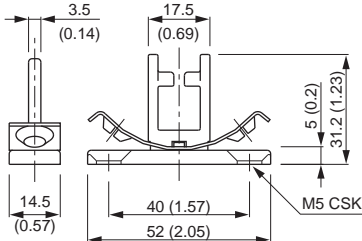

Actuators*

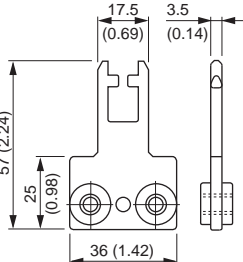
Item	Description	Approximate Dimensions [mm (in.)]	Cat. No.
	Standard actuator	 <p>Dimensions: 4 (0.16), 10 (0.39), 30 (1.18), 50 (1.97), 2 x M5, 3.5 (0.14), 56 (2.2), 10.5 (0.41), 5 (0.2), 5 (0.2), 18 (0.71)</p>	440G-A07136
	Fully flex actuator	 <p>Dimensions: 24 (0.94), 90 (3.54), 77 (3.03), 10 (0.39), 21 (0.83), 18 (0.71), 9 (0.35), 75 (2.95), M5</p>	440G-A07269
	GD2 standard actuator	 <p>Dimensions: 18 (0.71), 4 (0.16), 36 (1.42), 40 (1.57), 52 (2.05), M5 CSK, 14.5 (0.57), 3.5 (0.14)</p>	440G-A27011
	Fully flex actuator	 <p>Dimensions: 6.8 (0.27), 18 (0.71), 52 (2.05), 40 (1.57), 31 (1.22), Adjusting screws, 2 x M3, 13 (0.51), 19 (0.75), 51 (2.01), 8 (0.31), 4 x Ø5.5 (0.22), 20 (0.79)</p>	440G-A27143
	Catch and Retainer Kit	 <p>Dimensions: 52 (2.05), 29 (1.14), 4 (0.16), 18 (0.71), 7.25 (0.29), 52 (20.5), 40 (1.57), 14.5 (0.57), 1.5 (0.06), 25.5 (1.0), 11.2 (0.44)</p>	440K-A11094

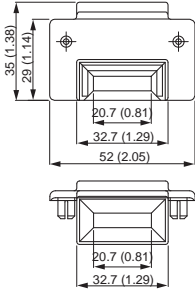
* See page 3-8 for Switch Compatibility table.

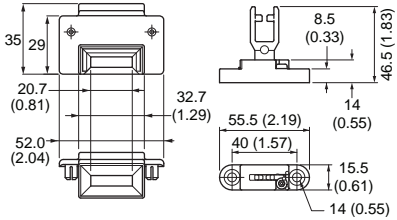
3-Interlock Switches

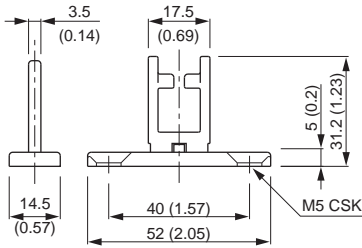
Actuators* (continued)

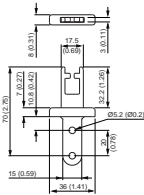





Item	Description	Approximate Dimensions [mm (in.)]	Cat. No.
	Standard actuator		440K-A11095
	GD2 flat actuator		440K-A11112
	Replacement Alignment Guide		440K-A11115
	Alignment guide with semi-flexible actuator		440K-A11144
	Standard actuator		440K-A11238
	Extended flat actuator		440K-A17116

* See page 3-8 for Switch Compatibility table.

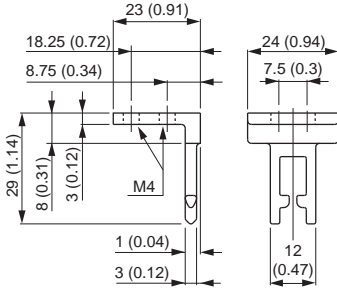
3-Interlock
Switches

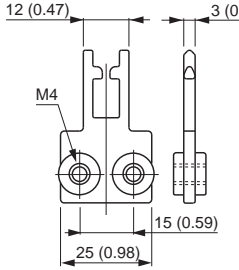
Safety Switches
Accessories
 Actuators

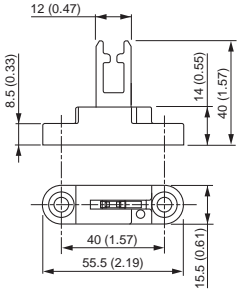

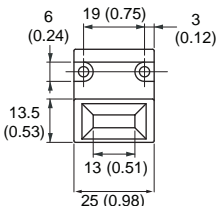
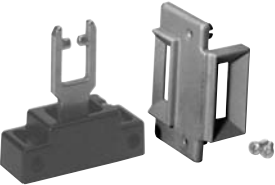
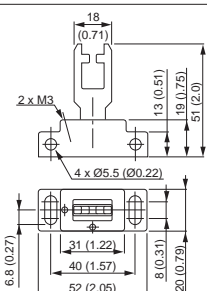





Actuators* (continued)

Item	Description	Approximate Dimensions [mm (in.)]	Cat. No.
	90° actuator, not to be used with metal alignment guide		440K-A21006
	Flat actuator, not to be used with metal alignment guide		440K-A21014
	Metal alignment guide with semi-flexible actuator		440K-A21030
	Metal Alignment Guide		440K-A21069
	Alignment guide with fully-flexible actuator		440K-A27010







* See page 3-8 for Switch Compatibility table.

3-Interlock Switches

Beacons and Bulbs

Item	Description	Cat. No.
	Indicator, M20 Conduit Pilot Light—Amber Lens T-3 1/4 Insert Use T-3 1/4 Bulb (Sold Separately)	440A-A19001
	Indicator, M20 Conduit Pilot Light—Red Lens T-3 1/4 Insert Use T-3 1/4 Bulb (Sold Separately)	440A-A19002
	Indicator, 1/2 inch NPT Conduit Pilot Light—Amber Lens T-3 1/4 Insert Use T-3 1/4 Bulb (Sold Separately)	440A-A19005
	Indicator, 1/2 inch NPT Conduit Pilot Light—Red Lens T-3 1/4 Insert Use T-3 1/4 Bulb (Sold Separately)	440A-A19007
	Bulb, 24V for Conduit Pilot Light 2.8W T-3 1/4 Bulb, Miniature Screw Base	440A-A09056
	Bulb, 110V for Conduit Pilot Light 2.6W T-3 1/4 Bulb, Miniature Screw Base	440A-A09055
	Bulb, 240V for Conduit Pilot Light 0.75W T-3 1/4 Bulb, Miniature Screw Base	440A-A09054
	Red LED Bulb, 24V AC/DC for Conduit Pilot Light Bayonet Style Insert	800T-N319R
	Amber LED Bulb, 24V AC/DC for Conduit Pilot Light Bayonet Style Insert	800T-N319A
	Red LED Bulb, 120V AC for Conduit Pilot Light Bayonet Style Insert	800T-N320R
	Amber LED Bulb, 120V AC for Conduit Pilot Light Bayonet Style Insert	800T-N320A

Conduit Accessories









Item	Description	Cat. No.
	Blanking plug, M20 conduit	440A-A07265
	Cable Grip, M16 Conduit, Accommodates Cable Diameter 4...7 mm (0.27...0.16 in.)	440A-A09004
	Cable grip, M20 conduit, accommodates cable diameter 7...10.5 mm (0.27...0.41 in.)	440A-A09028
	Adaptor, conduit, M20 to 1/2 inch NPT, plastic	440A-A09042
	Adaptor, Conduit, 1/2 inch NPT to M16, Brass	440A-A09093
	Adaptor, Conduit, M16 to 1/2 inch NPT, Brass	440A-A09094

Safety Switches



Accessories

Replacement and Dust Covers, Emergency Override, and Flex Release

Replacement Covers

Item	Description	Cat. No.
	Elf™	440A-A33085
	Cadet™	440A-A21115
	Trojan T15	440A-A11499
	Trojan 5 Standard Models Only	440A-A11495
	Trojan T5 GD2	440A-A11496
	Trojan T6 Standard Models Only	440A-A11497
	Trojan T6 GD2	440A-A11498
	440G-MT No LED, No Override	440G-MT47120
	440G-MT LED and Override	440G-MT47123
	Cover for TLS-1 with external override key for series D and earlier	440G-A27140
	Cover for TLS-3 with external override key for series D and earlier	440G-A27142
	Cover for TLS-1 with override key attached for series D and earlier	440G-A27207
	Cover for TLS-3 with override key attached for series D and earlier	440G-A27208
	Atlas Replacement End Cap	440G-A07180

Dust Covers

Item	Applicable Switch	Cat. No.
	Elf Cadet	440K-A17182
	Trojan T15, T5, and T6 All Models MT G2 440G-MT	440K-A17180
	TLS-GD2	440K-A17183
	Atlas 5	440K-A17181

Emergency Override

Item	Description	Cat. No.
	TLS-GD2/440G-MT Solenoid Emergency Override (See Warning below.)	440G-A36026



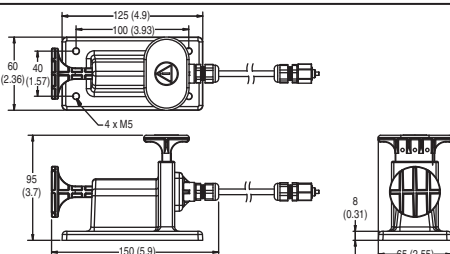

WARNING: Do not attach the Emergency Override Key to the TLS-GD2/440G-MT switch.

Flex Release



Item	Description	Approximate Dimensions [mm (in.)]	Cat. No.
	Flexible Release—1 m (3.28 ft) Cable		440G-A27356
	Flexible Release—3 m (9.84 ft) Cable		440G-A27357

3-Interlock Switches

Tools

Item	Description	Cat. No.
	Security Bit	440A-A09015
	Screwdriver Including Security Bit	440A-A09018

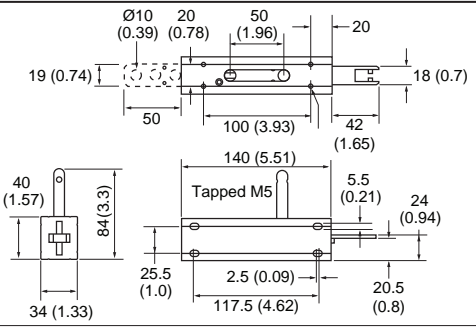
Door Handles

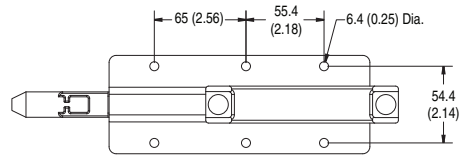
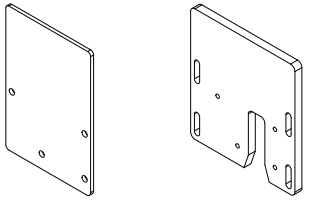
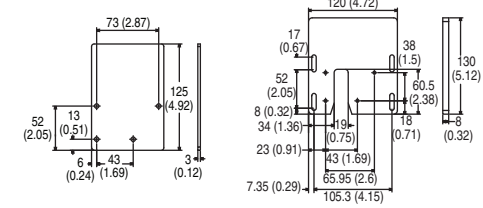
Item	Description	Dimensions [mm (in.)]	Cat. No.
	Sliding bolt actuator		440G-A27163
	Sliding Bolt		440K-AMDS
	Sliding Bolt Mounting Plate for TLS-GD2		440K-AMDSSMPB

3-Interlock Switches