



WESTCAR s.r.l.

ROTOFLUID

Fluid Couplings





INDEX	page
Operating principles and features of ROTOFLUID couplings.....	5
Installation options: standard and reverse mounting.....	6
Characteristic curves of motors with or without fluid couplings	7
Fluid couplings with delay fill chamber	8
Characteristic starting curves	9
ROTOFLUID coupling versions: ALFA and BETA.....	10
ROTOFLUID coupling versions for ALFA - for in-line mounting and BETA - with pulley	11
ROTOFLUID coupling selection diagram.....	12
ROTOFLUID coupling selection table for 50 Hz, 60 Hz UNEL MEC electric motors.....	13
Tables for ROTOFLUID ALFA couplings	
ROTOFLUID ALFA for metric shaft K, SCF K, DCF K.....	14
ROTOFLUID ALFA for inches shaft KA, SCF KA, DCF KA	15
ROTOFLUID ALFA with flanged shaft K-S, SCF K-S, DCF K-S.....	16
ROTOFLUID ALFA with elastic couplings K, SCF K, DCF K with RNV/FRNV and AB.....	17
ROTOFLUID ALFA with elastic element and brake disc K, SCF K, DCF K with RNPAV/FRNPAV and ADB.....	18
ROTOFLUID ALFA with elastic element and brake drum K, SCF K, DCF K with RND/FRND and AFF	19
ROTOFLUID ALFA with gear couplings RE / REU WAG-G/GU, SCF WAG-G/GU, DCF WAG-G/GU	20
ROTOFLUID ALFA with brake drum FPU / brake disc DPU WAG-GPU/GPUU, SCF WAG-GPU/GPUU, DCF WAG-GPU/GPUU ..	21
ROTOFLUID ALFA with disc coupling HBSX KLM-RH, KLM-L.....	22
ROTOFLUID ALFA with brake drum FFL / brake disc DFL KLM-LF/LLF, SCF KLM-LF/LLF, DCF KLM-LF/LLF	23
ROTOFLUID ALFA for reverse mounting NY-FB, NY-SCF-FB, NY DCF-FB	24
ROTOFLUID ALFA with bell housing CKS	25
Tables couplings ROTOFLUID BETA	
ROTOFLUID BETA with and without delay fill chamber J, X, Z - SCF J, X, Z - DCF J, X, Z.....	26
COMPLEMENTS	
Bores and keyways table for fluid coupling shaft.....	27
Protection Plugs	28
Electric-Thermal switch equipment type ET	29
Device for speed and temperature control T09	30
Electronic device for overload control SCD.....	31
ITC Infrared Temperature Controller.....	32
Screw puller VE type - pulling off system SE type.....	33
ROTOFLUID couplings Moment of inertia.....	34
Instructions for filling and replacement of oil in ROTOFLUID coupling	35
ROTOFLUID coupling special versions.....	36
Fields of application.....	37
Technical sheet for coupling selection	38

INDEX OF TECHNICAL SHEETS

page

10-002B EN ROTOFLUID coupling selection table for 50 Hz, 60 Hz UNEL MEC electric motors	13
10-019E EN Bores and keyways table for fluid coupling shaft.....	27
10-035B EN ROTOFLUID couplings Moment of inertia.....	34
10-037A EN Operating principles and features of ROTOFLUID couplings	5
10-038B EN Installation options: standard and reverse mounting.....	6
10-052A EN Fields of application	37
10-057E EN ROTOFLUID coupling versions for ALFA - for in-line mounting and BETA - with pulley.....	11
10-059 EN Technical sheet for coupling selection.....	38
10-061A EN Characteristic curves of motors with or without fluid couplings.....	7
10-080A EN Characteristic starting curves	9
10-100C EN ROTOFLUID coupling selection diagram.....	12
10-141A EN Fluid couplings with delay fill chamber.....	8
10-180 EN ROTOFLUID coupling versions: ALFA and BETA.....	10
10-190A EN Instructions for replacement and variation of oil quantity.....	35
10-195 EN ROTOFLUID coupling special versions.....	36
45-015D EN ROTOFLUID ALFA for metric shaft K, SCF K, DCF K.....	14
45-017 EN ROTOFLUID ALFA for inches shaft KA, SCF KA, DCF KA.....	15
45-020D EN ROTOFLUID ALFA with flanged hub K-S, SCF K-S, DCF K-S.....	16
45-090 EN ROTOFLUID ALFA with elastic coupling K, SCF K, DCF K with RNV/FRNV e AB.....	17
45-091A EN ROTOFLUID ALFA with elastic element and brake disc K, SCF K, DCF K with RNP/FRNP e ADB.....	18
45-093A EN ROTOFLUID ALFA with elastic element and brake drum K, SCF K, DCF K with RND/FRND e AFF.....	19
45-113G EN ROTOFLUID ALFA with gear couplings RE / REU WAG-G/GU, SCF WAG-G/GU, DCF WAG-G/GU.....	20
45-120A EN ROTOFLUID ALFA with brake drum FPU / brake disc DPU WAG-GPU/GPUU, SCF WAG-GPU/GPUU, DCF WAG-GPU/GPUU.....	21
45-215A EN ROTOFLUID BETA with and without delay fill chamber J, X, Z - SCF J, X, Z - DCF J, X, Z.....	26
45-281A EN ROTOFLUID ALFA with bell housing CKS.....	25
45-300E EN ROTOFLUID ALFA with disc coupling HBSX KLM-RH, KLM-L	22
45-305C EN ROTOFLUID ALFA with brake drum FFL / brake disc DFL KLM-LF/LLF, SCF KLM-LF/LLF, DCF KLM-LF/LLF.....	23
45-400A EN ROTOFLUID ALFA for reverse mounting NY-FB, NY-SCF-FB, NY DCF-FB.....	24
80-004B EN Electric-Thermal switch equipment type ET	29
80-022C EN Electronic device for overload control SCD.....	31
80-035 EN Protection Plugs.....	28
80-062 EN Device for speed and temperature control T09.....	30
80-065 EN ITC: Infrared Temperature Controller.....	32
90-005B EN Screw puller VE type - pulling off system SE type.....	33

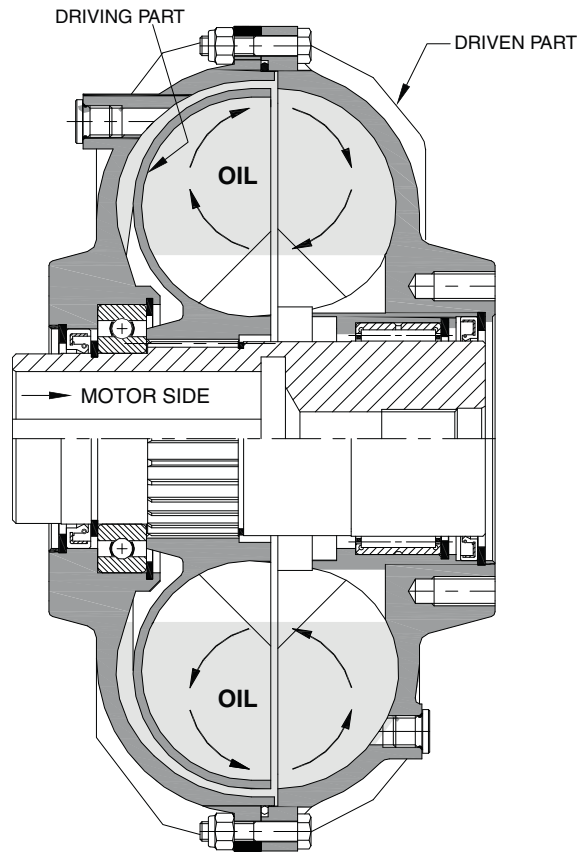

The ROTOFLUID fluid coupling is designed to provide your plant with optimum reliability and durability. It is fitted between the motor (drive) and machine (driven component).

The ROTOFLUID fluid coupling comprises basically two impellers, with radial blades, opposed to each other, one connected to the motor shaft and the other to the input shaft of the Driven Equipment or Machine. The ROTOFLUID fluid coupling acts like a centrifugal clutch, by driving an impeller, the oil passing from the blades to the driven part, which acts as a driven impeller, transmits the power to the Equipment or Machine.

The oil, which fills the fluid coupling, transfers the torque and also lubricates moving parts.

Fluid couplings are the easiest and cheapest way of creating a perfectly Flexible Drive Train, because no mechanical parts are necessary between the motor and the Equipment or Machine being driven. Without mechanical parts, there is practically no wear. Losses in the fluid coupling become power losses according to the following formula:

$$S\% = \frac{n_m - n_u}{n_m} \times 100$$

where:

n_m = motor speed (rpm)

n_u = output speed from the fluid coupling (rpm)

The elasticity of the fluid coupling solves problems of power peaks between electric motors and driven machines.

THE ADVANTAGES OF USING FLUID COUPLINGS

- easy start-up with gradual acceleration of the driven component
- automatic load speed adjustment on the basis of the synchronous speed of two ore more motors
- the drive train is protected againts overloads
- torsional vibrations are dampened
- the tourque transmitted complies with pre-set values
- direct on-line start electric motors can be used, without star-delta starters or slip-ring motors with rheostat

THE ADVANTAGES OF USING ROTOFUID FLUID COUPLINGS

- a large range of accessories
- interchangeable accessories on the basic cell
- the dimensions of the shaft-pulley system are perfectly suited to the needs of the drive train
- all fluid couplings that utilise a belt drive are fitted with ball bearings to guarantee above- standard radial loads
- all the fluid couplings used for Horizontal applications are fitted with a relevant elastic flexible coupling, which gives the advantage to the user, of being able to replace the Flexible element, by removing it radially from the coupling, without either disturbing the Motor or the Driven Equipment or Machine.

STANDARD ASSEMBLY

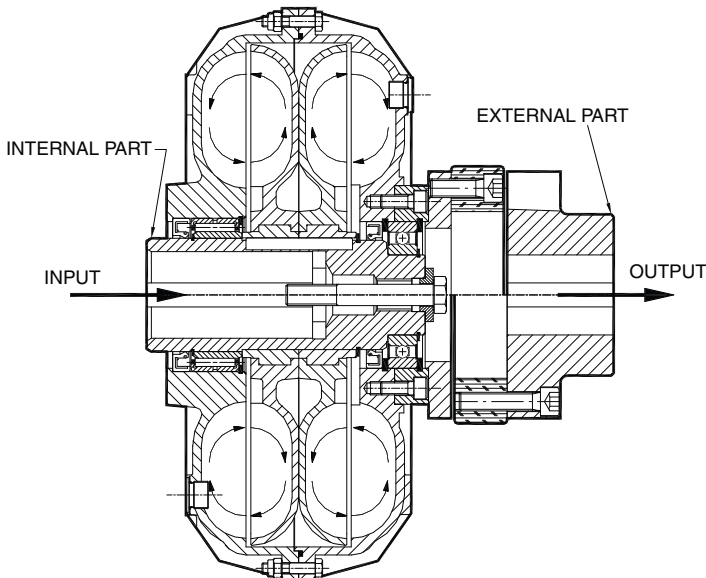

REVERSE ASSEMBLY

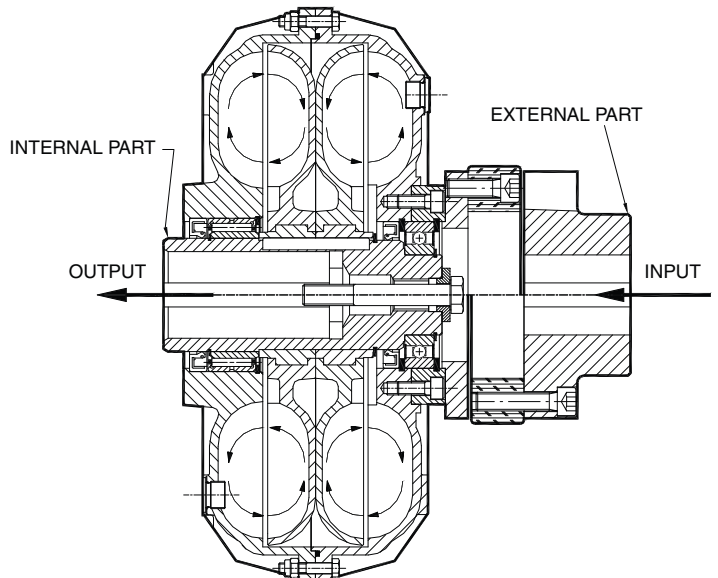

ADVANTAGES OF STANDARD ASSEMBLY

In STANDARD assemblies, the fluid coupling is mounted with the inner part connected to the motor shaft.

This is common for couplings with pulleys and in line application, providing the following benefits:

- standardisation of bores in compliance with UNEL MEC motors
- during start-up motor is less loaded due the low inertia of the inner part, operating speed is reach with reduced current peak
- in inline applications, where a brake is required, disc/drum is mounted directly on the reduction gear shaft without increasing the axial length of the coupling
- in couplings with delay fill chambers, start-up is smoother because the oil pass from the delay fill chamber into the circuit due to centrifugal force reducing the pick torque
- flexible element mounted on the fluid coupling is less stressed, because the torque is transmitted by the fluid and not with a direct connection to the motor.

ADVANTAGES OF REVERSE ASSEMBLY

In a REVERSE assembly, the fluid coupling is mounted with the outer part connected to the motor shaft.

This type of assembly is possible whenever the fluid coupling is mounted between motor and gear box.

For couplings with a V Pulley, the unit must be fitted to the driving shaft, pay attention between the driving and driven pulley ratio. In case of need consult WESTCAR srl.

This type of assembly has the following important benefits:

- higher heat dissipation, recommended in case of extended and frequent motor start-ups
- easier regulation and filling of the oil level in the coupling, since the external part can be rotated without moving the driven machine
- **IMPORTANT!** When the coupling is mounted with THERMAL SWITCHING PIN, even in case of jam of the driven side the function of the safety device is guarantee.

In the absence of special needs or requests, the coupling is supplied in STANDARD configuration.

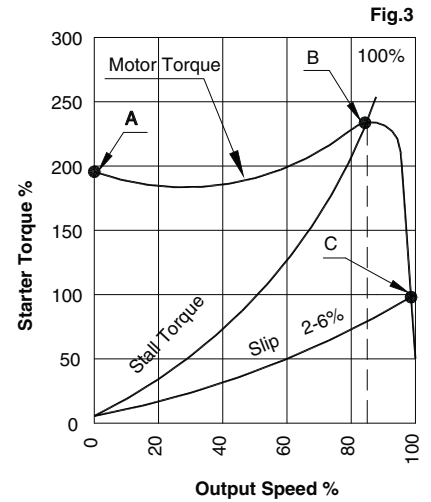
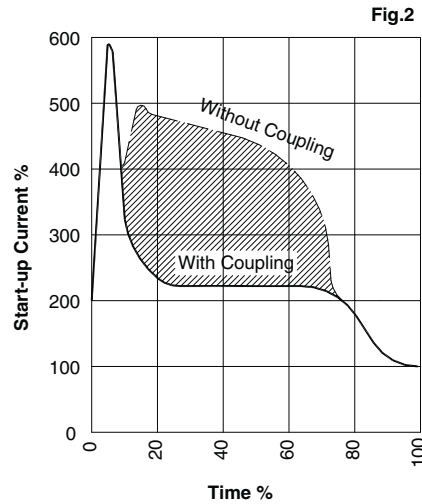
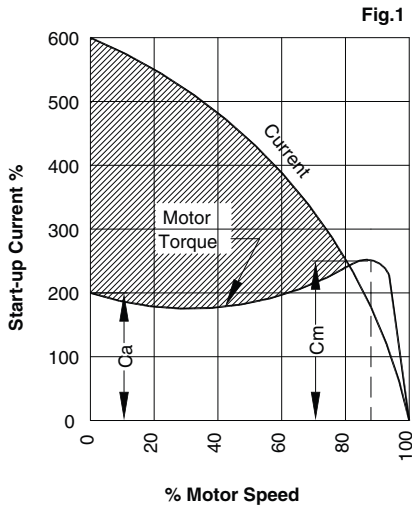

START-UP WITHOUT FLUID COUPLING

Figure 1 represents the typical start-up of an electric motor directly connected to the load. The dotted line represents the energy lost bringing the motor and load up to operating speed.

As can be seen, direct start-up has the following disadvantages:

- the difference between start-up torque (C_a) and the load requirement (C_m) is very low; the maximum torque is between 80%-85% of the operating speed
- the current absorbed during start-up may be up to 6 times the rated current, causing electrical overloads and higher costs, an increase in motor temperature and fewer possible start-ups.
- difficulty of application when a high starting torque is required.

START-UP WITH ROTOFUID FLUID COUPLING

Figure 2 compares the current absorbed by the electric motor starter with and without hydrodynamic coupling.

The first curve "Without coupling" is a start-up with direct connection in short-circuit. The second curve "With coupling" is the same start-up interposed with the hydrodynamic coupling. The crossed-out part represents the difference in energy used for the same start-up with and without hydrodynamic coupling.

In the first curve "Without coupling" the current reaches a peak of about six times the nominal and persists with high values up to the rated engine speed.

In the second curve "With coupling" the peak current remains high for only a few seconds (energy required to accelerate the motor rotor only) and goes down to acceptable values for the time necessary to bring the machine to scheme.

When the hydrodynamic coupling ROTOFUID is interposed between the electric motor and the driven machine, the motor can start-up in short circuit.

CHARACTERISTIC CURVES FOR START-UP WITH FLUID COUPLING

Figure 3 shows a characteristic torque curve for an electric motor, the stall curve of the fluid coupling and the slip curve at operating speed. The fluid coupling allows the motor to reach 80-85% speed in a few seconds (shift from point A to point B) where it meets the stall curve of the fluid coupling (slip=100%), the point of maximum motor torque.

Point C is the point of functioning of the fluid coupling after the motor has reached operating speed.

The use of a fluid coupling with a delay fill chamber limits maximum torque during start-up, without prejudicing slipping in normal functioning. This allows the motor to quickly increase speed [revs] without hitting the resistant torque (as if it started unloaded).

A fluid coupling with a delay fill feature is fitted with additional chamber in order to reduce the quantity of oil in the working circuit (see Fig.1). The chamber is in contact with the circuit via calibrated nozzles, which can be set as required (see Fig.2). The variation in the calibrated nozzle holes changes the time it takes for the oil in the chamber to reach the working circuit, thereby, increasing or decreasing start-up time for the driven machine.

When all the oil has flowed from the chamber into the circuit, the fluid coupling reaches the rated speed, transmitting the required torque with minimum slippage (see Fig.3).

Fluid couplings may be fitted with either a single or dual delay fill chamber.

With a single delay fill chamber, Ca/Cn torque limitation varies from 180% to 150%, adjusting the quantity of oil.

With a double delay fill chamber, Ca/Cn torque limitation varies from 150% to 120%, adjusting the quantity of oil.

The advantages of delay fill chambers are enhanced as the power requirement rises.

SCF and DCF delay fill chambers are available from size 30 to size 95P.

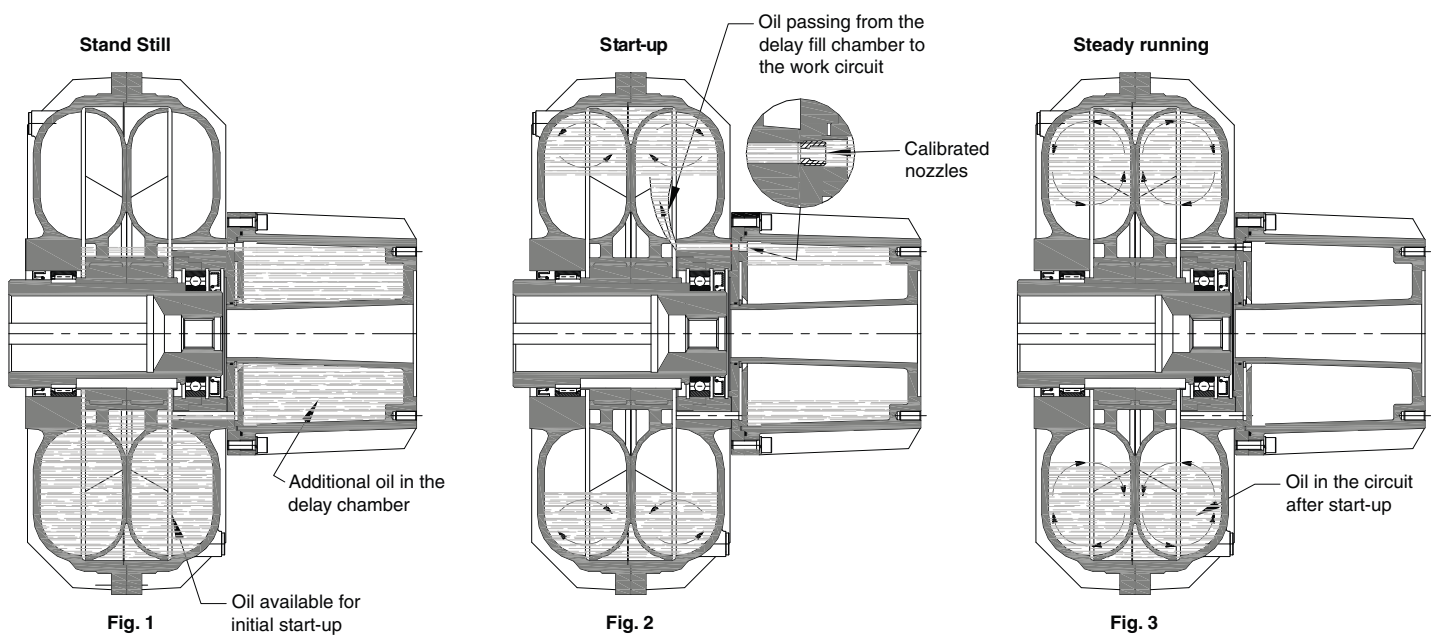

ADVANTAGES

- Low energy loss even where inertia is high
- Start-up time can be adjusted
- Start-up torque is limited to pre-set values without affecting slip
- Limitation of start-up current prolongs the life of the motor
- For controls with several drives the coupling automatically adjusts the load speed on the basis of synchronous speed
- More start-ups per hour

The ROTOFLUID SCF/DCF peculiarities are more evident comparing the curve of the ROTOFLUID coupling without delay chamber.

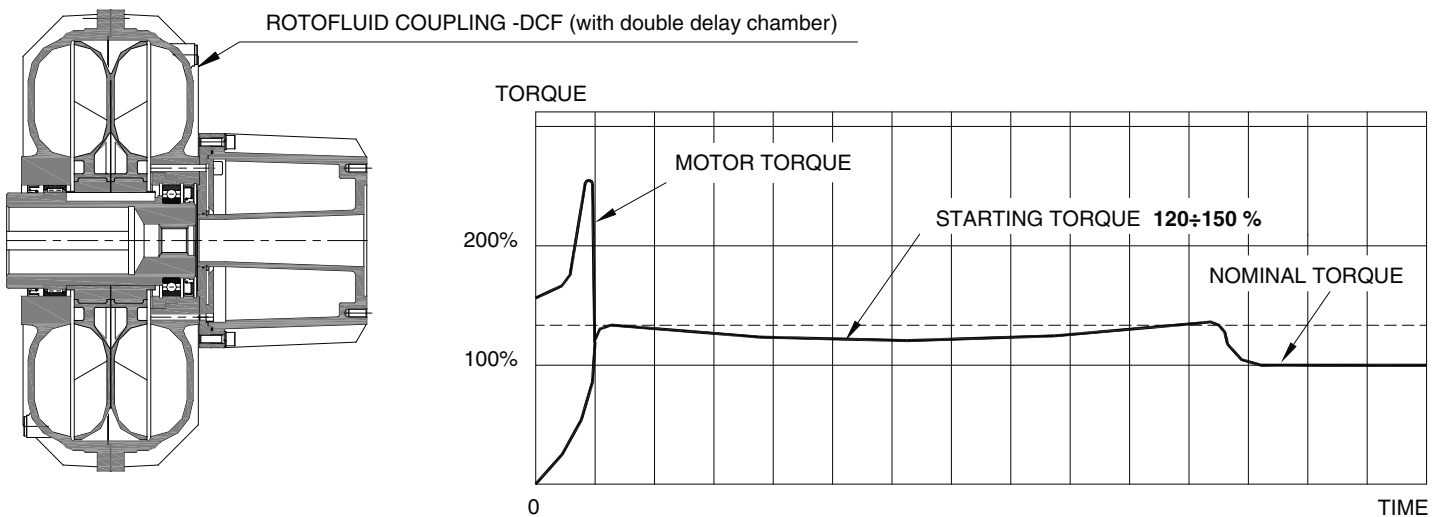
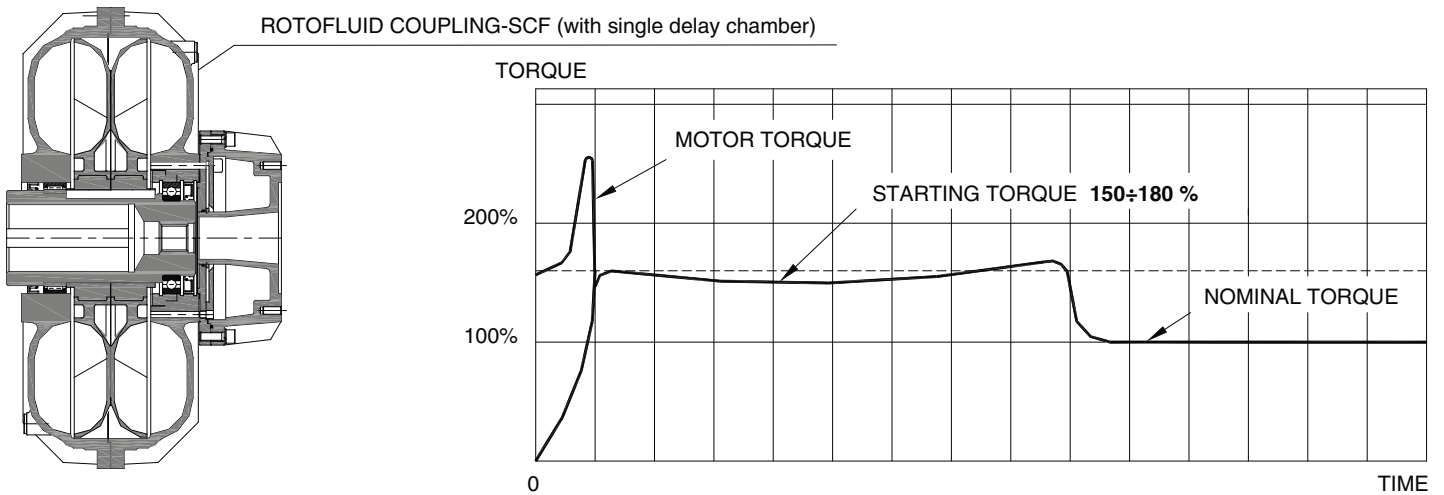
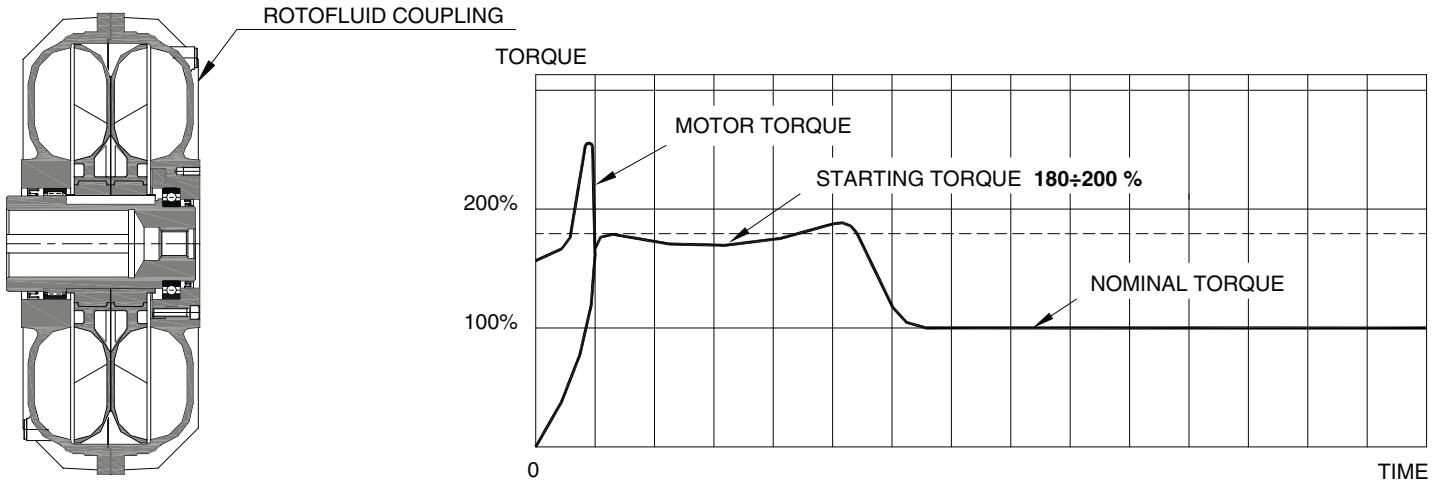

ROTOFLUID COUPLING ALFA

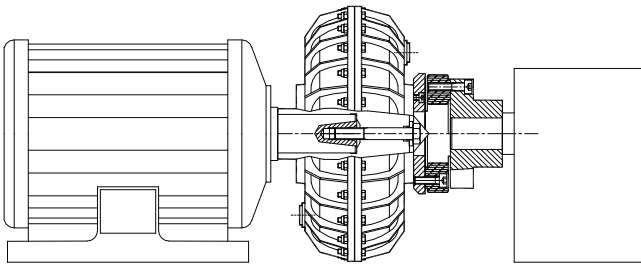

ROTOFLUID COUPLINGS **ALFA** are used for in-line transmission between equipment.

ALFA couplings can be supplied with several accessories that allow easy installations and maintenance.

ROTOFLUID COUPLING BETA

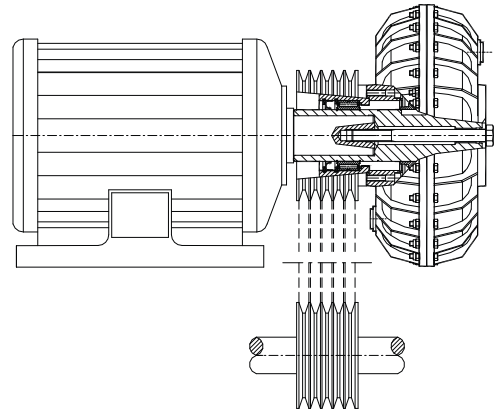

ROTOFLUID COUPLINGS **BETA** are used for pulleys transmission equipment between parallel shafts.

These couplings are available also with Delay Fill Chambers.

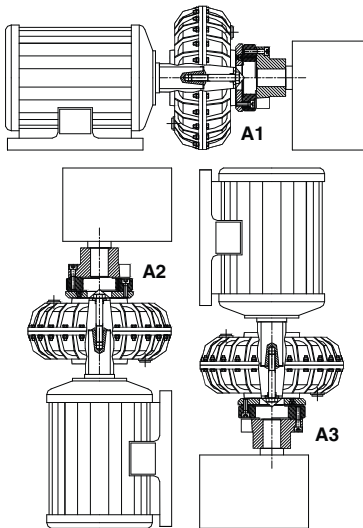

INSTALLATION OPTIONS

ROTOFLUID couplings **ALFA** and **BETA** can be horizontally or vertically mounted, as per examples showed for installation A2 – A3 – B2 – B3.

For more details or specific request, please contact WESTCAR srl.

ALFA and **BETA** couplings are supplied with fixing screw.

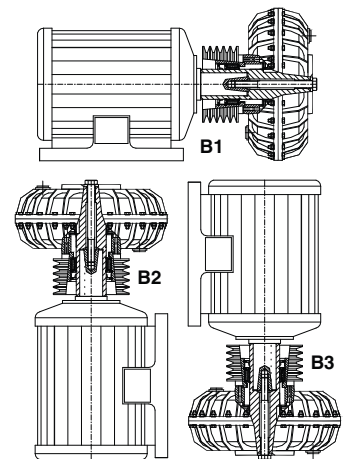

IMPORTANT

COUPLING WITH DELAY CHAMBER CORRECT INSTALLATION

HORIZONTAL SHAFT

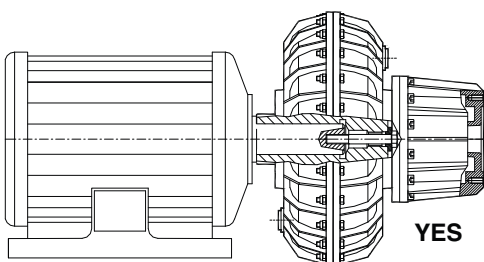

VERTICAL SHAFT WITH
DOWNWARD DELAY CHAMBER

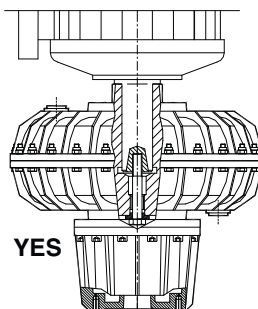

VERTICAL SHAFT WITH UPWARD
DELAY CHAMBER

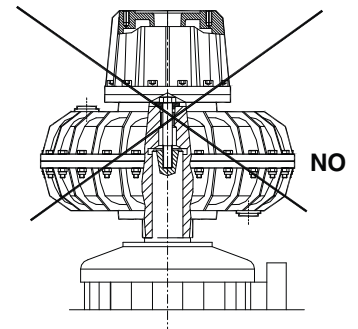

ROTOFLUID ALFA without accessories

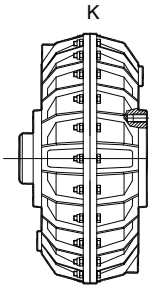

PAG. 14

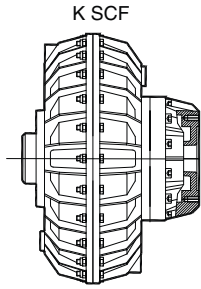

PAG. 14

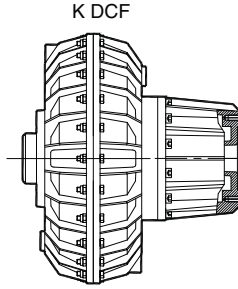

PAG. 14

ROTOFLUID ALFA K-S

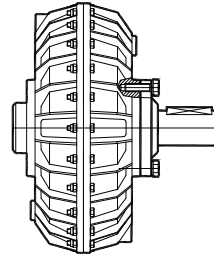

PAG. 16

ROTOFLUID ALFA CKS

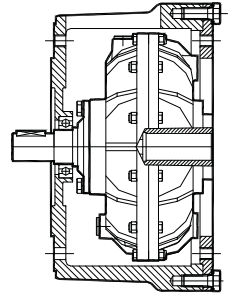

PAG. 25

ROTOFLUID ALFA K with elastic coupling

K-RNV
K-AB

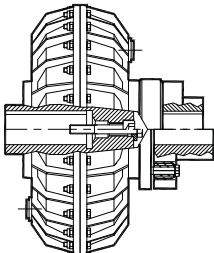

PAG. 17

ROTOFLUID ALFA K with elastic coupling and Brake Disc

K

RNPV
from 20 to 75P

ADB
from 80P to 1200

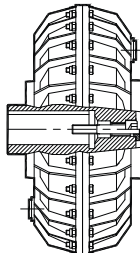

PAG. 18

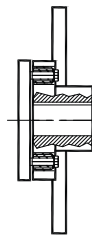
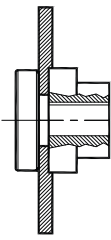

ROTOFLUID ALFA K with elastic coupling and Brake Drum

K

RND
from 20 to 75P

AFF
from 80P to 1200

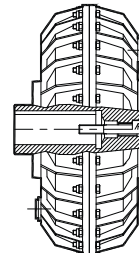

PAG. 19

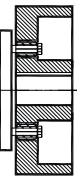
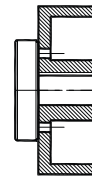

ALFA WAG-G

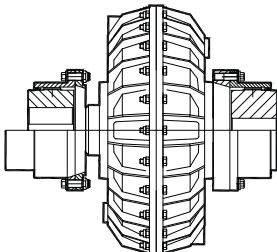

PAG. 20

ALFA WAG-GU

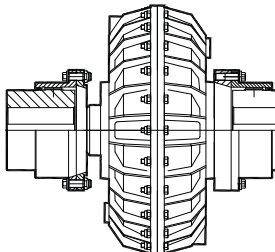

PAG. 20

ALFA WAG-GPU

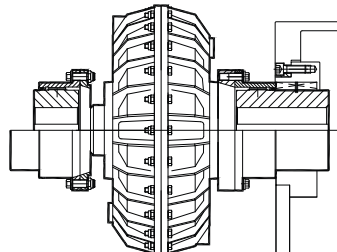

ALFA WAG-GPUU
PAG. 21

FPU

DPU

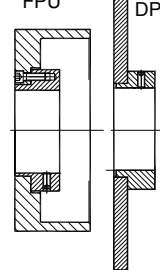

ALFA KLM-RH

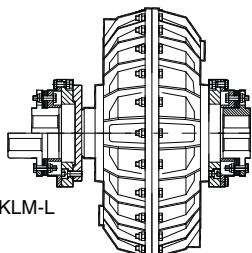

PAG. 22

ALFA KLM-L

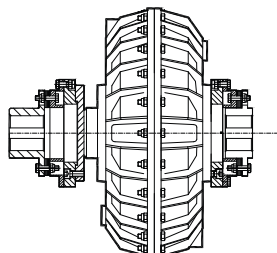

PAG. 22

ALFA KLM-LF

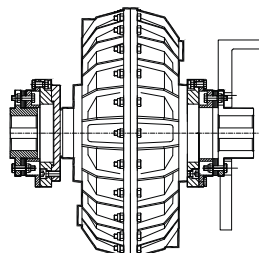

PAG. 23

ALFA KLM-LLF

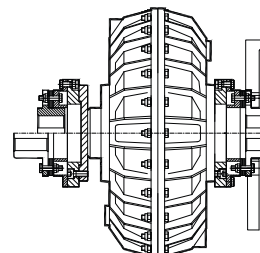

PAG. 23

FFL

DFL

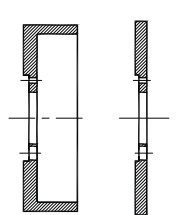

ALFA NY-FB

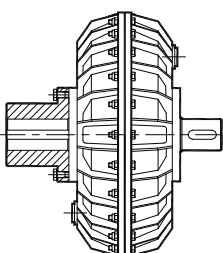

PAG. 24

BETA J

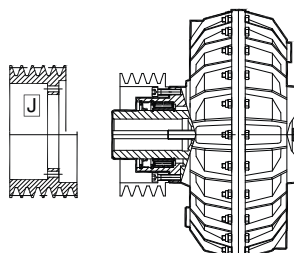

PAG. 26

BETA X

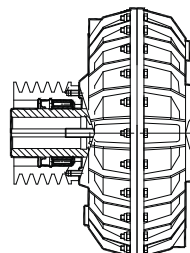

PAG. 26

BETA Z

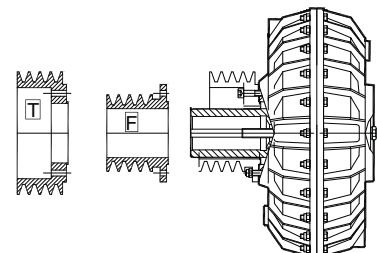

PAG. 26

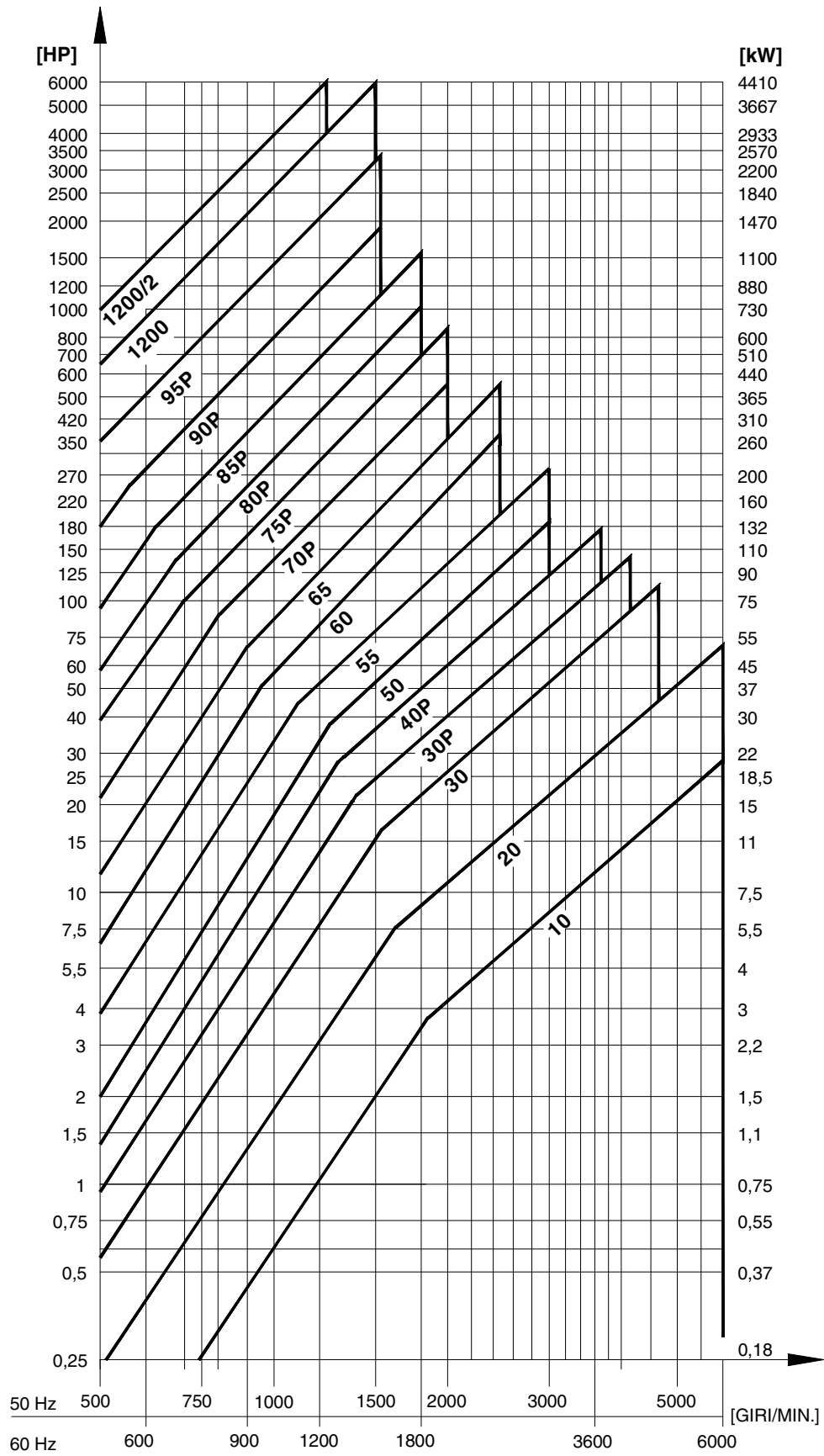

Select coupling size on input power and speed
 The curves show limit capacity of couplings
 If the selection point falls on or close to the max capacity limit line of a given coupling size, please contact WESTCAR

STANDARD ELECTRIC MOTORS		Motor speed 50 Hz											Motor speed 60 Hz											
		8 poles 750 rpm			6 poles 1000 rpm			4 poles 1500 rpm			2 poles 3000 rpm		6 poles 1200 rpm			4 poles 1800 rpm								
Type	Ø Shaft	kW	HP	Coupling	kW	HP	Coupling	kW	HP	Coupling	kW	HP	Coupling	kW	HP	Coupling	kW	HP	Coupling					
71	14	-	-	-	0,25	0,33	10	0,25	0,33	10	0,37	0,5	10	0,25	0,33	10	0,25	0,33	10	0,37	0,5			
80	19	-	-	-	0,37	0,5		0,37	0,5		0,55	0,75		0,75	1		0,75	1		0,55	0,75	0,75	1	0,75
90S	24	-	-	-	0,75	1	20	1,1	1,5	20	1,5	2	10	0,75	1	20	1,1	1,5	20	1,5	2	20	1,5	2
90L	24	0,55	0,75	20	1,1	1,5		1,5	2		1,5	2		2,2	3		1,5	2		1,5	2		1,5	2
100L	28	1,1	1,5	30	1,5	2	30	2,2	3	20	3	4	10	1,5	2	20	2,2	3	20	3	4	20	3	4
112M	28	1,5	2	30P	2,2	3		4	5,5		4	5,5		4	5,5		4	5,5		4	5,5		4	5,5
132	38	-	-		30P	3	4	30P	5,5	7,5	30	5,5	7,5	20	3	4	30	5,5	7,5	30	5,5	7,5	20	5,5
132M	38	3	4	40P	4	5,5	5,5		7,5	7,5		10	-		-	4		5,5	5,5		7,5	7,5		10
160M	42	4	5,5	50	7,5	10	40P	11	15	30P	11	15	30	7,5	10	30P	11	15	30	11	15	30	11	15
160L	42	7,5	10	55	11	15		15	20		15	20		18,5	25		15	20		18,5	25		15	20
180M	48	-	-		60	-	-	50	18,5	25	40P	18,5	25	30	-	-	40P	18,5	25	30	18,5	25	30	18,5
180L	48	11	15	15		20	15		20	22		30	22		30	22		30	-		-	22		30
200L	55	15	20	60	18,5	25	55	30	40	50	30	40	30P	22	30	50	30	40	40P	30	40	40P	30	40
225S	60	18,5	25		-	-		-	37		50	-		-	-		-	37		50	-		-	37
225M	55 60	- 22	- 30	65	- 30	- 40	60	- 45	- 60	55	45	60	40P	- 30	- 40	55	- 45	- 60	55	- 45	- 60	55	- 45	- 60
250M	60 65	- 30	- 40		- 37	- 50		- 65	- 55		- 75	- 55		- 75	55		75	55		75	55		75	55
280S	65 75	- 37	- 50	70P	- 45	- 60	65	- 75	- 100	60	75	100	50	- 45	- 60	60	- 75	- 100	60	- 75	- 100	60	- 75	- 100
280M	65 75	- 45	- 60		- 55	- 75		- 70P	- 90		- 125	- 90		- 125	90		125	90		125	90		125	90
315S	65 80	- 55	- 75	75P	- 75	- 100	70P	- 110	- 150	65	110	150	55	- 75	- 100	65	- 110	- 150	65	- 110	- 150	60	- 110	- 150
315M	65	-	-		-	-		-	-		-	-		-	132		180	132		180	132		180	132
355S	80 100	- 132	- 180	85P	- 160	- 220	80P	- 250	- 340	75P	-	-	-	-	-	-	-	-	-	-	-	-	-	-
355M	80 100	- 160	- 220		- 200	- 270		- 85P	- 315		- 430	- 315	- 430	-	-	-	-	-	-	-	-	-	-	-
		330	450	90P	370	500	85P	510	700	80P				310	420	80P	440	600	75P					
		600	800	95P	600	800	90P	810	1100	85P				440	600	85P	700	950	80P					
		800	1100	1200	1000	1360	95P	1300	1740	90P				800	1100	90P	1000	1360	85P					
		1000	1360	1200D	2000	2720	1200	2300	3100	95P				1380	1880	95P								
					3300	4500	1200D	3850	5250	1200				2580	3500	1200								
														4200	5710	1200D								

• For couplings at 3000 rpm, ask for balancing required

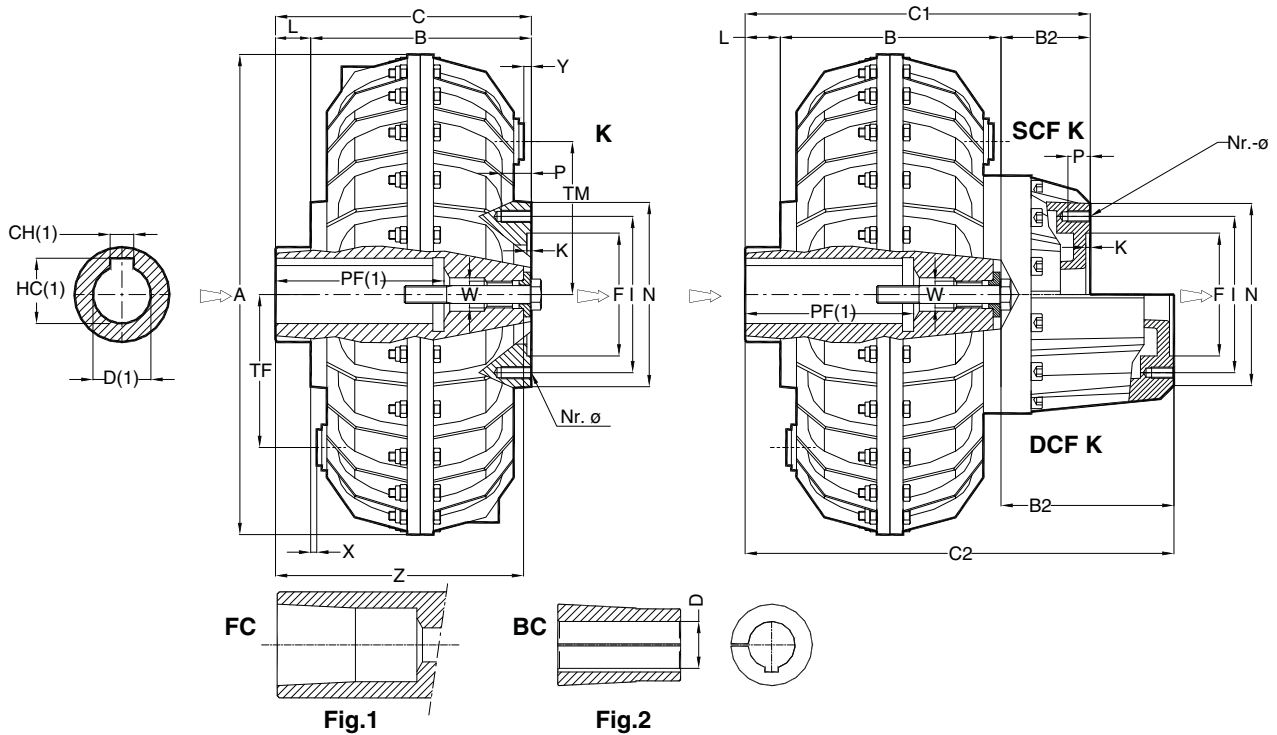

NOTES: (1) for bore and keyway dimensions see sheet 10-019E / (2) the arrows \Rightarrow indicate input and output

ROTOFLUID SIZE	Dimensions in mm													K			SCF K				DCF K							
	Bore D	A	B	K	I	L	N	Nr.ø	P	TF TM	W	X	Y	Z	Type	mm		kg*	Type	mm		kg*	Type	mm		kg*		
																C	F ^{H7}			B2	C1			F ^{H7}	W.		B2	C2
10	19-24	193	88	4	60	10	75	6-M6	12	66	M10	0,5	0	94	K1	98	47	4	--	--	--	--	--	--	--	--	--	--
20	24-28	230	115		78		94	6-M8	80	M14	2	7	120	K1	125	62	6	--	--	--	--	--	--	--	--	--	--	--
30	38 [□] -42 [□]	290	150	4	100	12	114	8-M8	16	110	M24	9	9	157,5	K1	162	*75	13,2	K2	55	217	72	15,6	K2	95	257	72	16,2
30P		327													K1				K2					23,4				
40P	42 [□] -48 [□]	338	183	4,5	125	15	145	8-M10	22	130	M30	11	24	194	K1	198	*100	22	K2	58	256	90	25,7	K2	130	328	90	27,2
50	48 [□] -55 [□] -60 [□]	430	154												140				25					165				
55	55 [□] -60 [□] -65 [□]	430	196	4,5	160	20	185	8-M10	22	205	M30	6	20	192	K2	192	46	K2	90	282	125	54,4	K2	170	362	125	58	
60	48 [□] -55 [□] -60 [□] 65 [□] -75 [□]	520	172												160								20					185
65	48 [□] -55 [□] -60 [□] 65 [□] -75 [□] -80 [□]	520	220	4,5	160	20	185	8-M10	22	205	M30	6	20	240	K2	240	66	K2	90	330	125	74,4	K2	170	410	125	78	
70P	80-90 100	640	190												195								50 90					225
*75P	80-90 100	245	4	195	20 35	225	8-M16	24	265	0	254 269	K2N K3N	265 280	117	K2N K3N	375 390	135	K2N K3N	490 505	147								
80P	Max.110 Max.125**	810	226	4	230	44 60	270	8-M18	28	325	M36	0	15	264 280	K2N K3N	270 286	180	K2N K3N	118	388 404	160	196	K2N K3N	218	488 504	160	208	
*85P	Max.125 Max.130														300													40
90P	Max.130 Max.140** Max.160***	1000	344	5	506	20 120 160	550	16-M20	32	416	M36	0	35	343 443 483	K2 K3 K5	364 464 504	445	K2 K3 K5	120	424 524 564	445	302 342 362	K2 K3 K5	200	504 604 644	445	317 357 377	
95P	Max.130 Max.140** Max.160***														466													13 120 160
1200	Max.190	1300	449	7	310	7	570		36	430		30	419	K2	456	220	1800	--	--	--	220	--	--	--	220	--		

* Weight with oil - ** Bore depth PF=210 - *** Bore depth PF=250

• Supplied with OVERSIZED CHAMBER SCFM or DCFM

♦ For 30 e 30P K FC: F^{H7}=72 - For 40P K FC: F^{H7}=90

□ Couplings with conical bore FC are supplied with Taper Bush BC and fixing screw (Fig. 1 and 2)

■ Taper Bushes are supplied without keyway

Couplings with cylindrical bore D will be supplied until end of stock

In case of mounting on shafts without shoulder contact WESTCAR

Example of order of a coupling with cylindrical bore: ALFA 55 K2 D=60

Example of order of a coupling for taper bush: ALFA 55 K2 FC

Example of order of a coupling with taper bush: ALFA 55 K2 FC + 55BC L15 D=60

DIMENSIONS ARE NOT BINDING

TAPER BUSH BC WITH FIXING SCREW						
COUPLING SIZE	Type	Standard D Bore			Max D Bore	
30/30P	3BC	-	38	42	48	
40P	4BC	-	42	48	50	
50	5BC	48	55	60	65	
55	5BC	48	55	60	65	
60	6BC	48	55	60	70	
65	6BC	48	55	60	70	

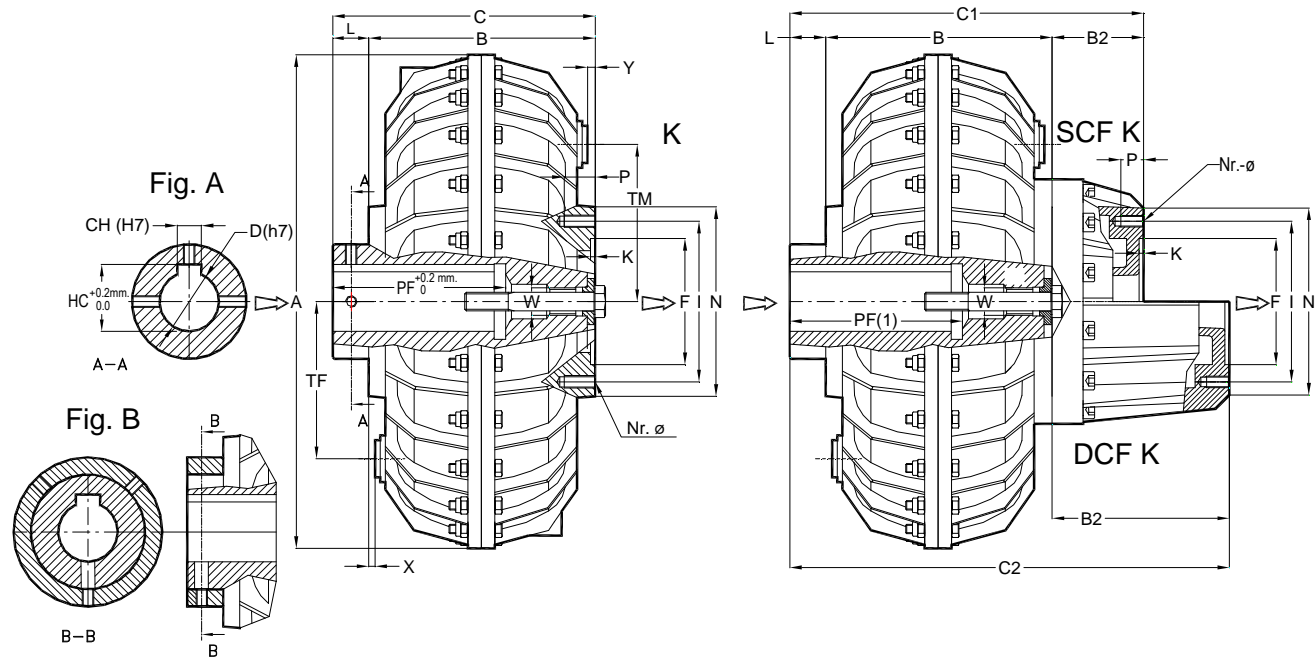

NOTE: (1) The arrows \Rightarrow indicate input and output

ROTOFLUID SIZE	inches		mm													K		SCF K			DCF K						
	Cyl. bore D	Fig.	A	B	F ^{H7}	K	I	L	N	Nr. ø	P	TF TM	W	X	Y	PF	Type	C	kg*	Type	B2	C1	Type	B2	C2	W.	
																	Weight	Weight	W.								
10 KA	0,875 1,125	A B	193	88	47	4	60	10 25,4	75	6-M6	12	66	M10	0,5	0	57,15 69,85	KA	98 113,4	4	--	--	--	--	--	--	--	--
20 KA	1,125 1,375	A B	230	115	52		78	10 25,4	94		8-M8	16	80	M14	2	7	69,85 85,72	KA	125 140,4	6	--	--	--	--	--	--	--
30 KA	1,625 1,875	A B	290	150	72	100	12 40	114	8-M8	16					110	M24	9	9	101,6 117,47	KA	162 190	13,2	KA	55	217 245	15,6	KA
30P KA	1,625 1,875	A B	327			100	12 40	114			8-M10	22	130	M24			6	6	101,6 117,47	KA	162 190	21	KA	23,4	KA	217 245	23,4
40P KA	1,625 1,875 2,125	A	338	183	90	125	15	145	8-M10	22					150	M30	11	24	101,6 117,47 133,35	KA	198	22	KA	58	256	25,7	KA
50 KA	1,875 2,125 2,375	A A B	430	154	110	140	25 25 32	165			8-M10	22	150	M30			20		117,47 133,35 149,22	KA	179 179 186	30	KA	80	259 259 266	35,8	KA
55 KA	2,125 2,375 2,875	A B B		196		140	15 20 54	185	8-M10	22					130	M24	6		133,35 149,22 184,15	KA	211 216 250	40	KA	90	291 296 330	45,8	KA
60 KA	2,375 2,875 3,375	A B B	520	172	125	160	20 57 108	185			8-M10	22	205	M30			20		149,22 184,15 215,9	KA	192 229 280	46,5 50,5	KA	90	282 319 370	54,4 56 66	KA
65 KA	2,375 2,875 3,375	A A B		220		160	20 20 61	185	8-M16	24					265	M36	6		149,22 184,15 215,9	KA	240 240 281	66	KA	90	330 330 371	74,4	KA
70P KA	2,875 3,375	A	640	190	150	195	50 90 126	225			8-M16	24	265	M36			15		184,15 215,9 250,82	KA	240 280 316	86	KA	110	350 390 426	99	KA
•75P KA	3,375 3,875	A B		245		195	40 76	225	8-M18	28					325	M36	0		215,9 250,82	KA	285 321	117	KA	118	395 431	135	KA
80P KA	3,375 3,875 4,750	A	810	226	160	230	44 44 76	270			8-M18	28	325	M36			15		215,9 250,82 250,82	KA	270 270 302	180	KA	118	388 388 420	196	KA
•85P KA	3,875 4,750	A		300		230	44 76	270	16-M20	32					416	M36	0		250,82	KA	340	252	KA	120	458	280	KA
90P KA	3,875 4,750 5,250	A	1000	344	445	506	40	550			16-M20	32	416	M36			35		250,82	KA	384	350	KA	120	504	302	KA
95P KA	3,875 4,750 5,250	A		466		506	550	16-M20	32	416					16-M20	32	416	M36	35		250,82	KA	506	505	KA	120	626

* Weight with oil • Supplied with OVERSIZED CHAMBER SCFM or DCFM ■ Reduced Dimension HC

DIMENSIONS ARE NOT BINDING

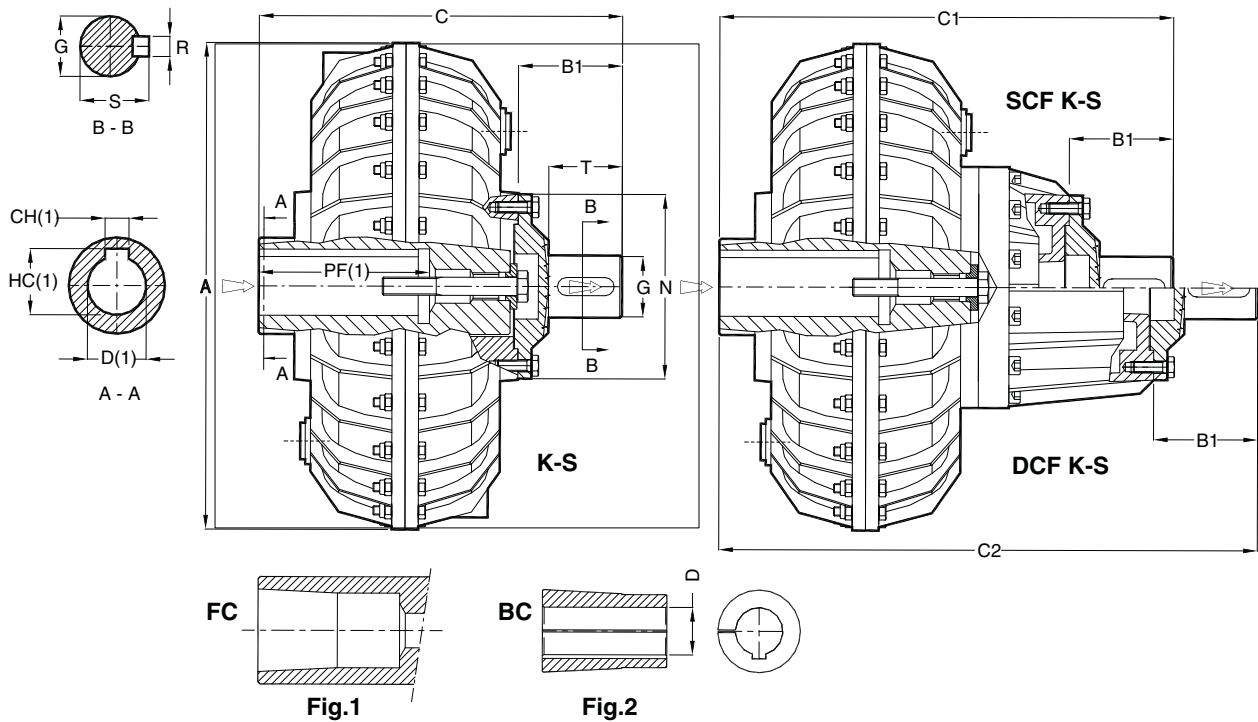

NOTES: (1) for bore and keyway dimensions see sheet 10-019E / (2) the arrows \triangleright indicate input and output

ROTOFLUID SIZE	Dimensions in mm								K-S		SCF K-S		DCF K-S				
									Type	mm	kg*	Type	mm	kg*	Type	mm	kg*
	Bore D	A	B1	G ^{h7}	N	R	S	T	C	Weight	C1	Weight	C2	Weight			
10	19-24	193	35	19	75	6	21,5	25	K1-S1	133	4,3	--	--	--	--	--	--
20	24-28	230	44	24	94	8	27	32	K1-S2	169	6,6	--	--	--	--	--	--
30	38 [□] -42 [□]	290	63	38	114	10	41	45	K1-S3	225	14,3	K2-S3	280	16,7	K2-S3	320	17,3
30P		327															
40P	42 [□] -48 [□]	338	76	48	145	14	51,5	55	K1-S4	274	24,2	K2-S4	332	27,9	K2-S4	404	29,4
50	48 [□] -55 [□] -60 [□]	430	92	55	165	16	59	65	K2-S5	271	33,2	K2-S5	351	39	K2-S5	426	41,2
55	55 [□] -60 [□] -65 [□]								K2-S5	303	43,2	K2-S5	383	49	K2-S6	458	51,2
60	48 [□] -55 [□] -60 [□] 65 [□] -75 [□]	520	110	60	185	18	64	80	K2-S6	302	50,6	K2-S6	392	59	K2-S6	472	62,6
65	48 [□] -55 [□] -60 [□] 65 [□] -75 [□] -80 [□]								K2-S6	350	70,6	K2-S6	440	79	K2-S6	520	82,6
70P	80-90 100	640	122	70	225	20	74,5	90	K2N-S7 K3N-S7	362 402	95	K2N-S6	472 512	108	K2N-S7	587 627	115
•75P	80-90 100								K2N-S7 K3N-S7	387 402	126	K2N-S7 K3N-S7	497 512	144	K2N-S7 K3N-S7	612 627	156
80P	Max.110 Max.125**	810	145	80	270	22	85	110	K2N-S8 K3N-S8	415 431	198	K2N-S8 K3N-S8	533 549	214	K2N-S8 K3N-S8	633 649	226
•85P	Max.125 Max.130								K2N-S8 K3N-S8	485	270	K2N-S8 K3N-S8	603 298	K2N-S8 K3N-S8	703 318		
90P	Max.130 Max.140** Max.160***	1000	220	110	550	28	116	180	K2-S9 K3-S9 K5-S9	584 684 724	416 456 476	K2-S9 K3-S9 K5-S9	644 744 784	368 408 428	K2-S9 K3-S9 K5-S9	724 824 864	383 423 443
95P	Max.130 Max.140** Max.160***								K2-S9 K3-S9 K5-S9	669 806 846	586 636 656	K2-S9 K3-S9 K5-S9	819 926 966	626 676 696	K2-S9 K3-S9 K5-S9	899 1006 1046	641 691 711
1200	Max.190	1300	290	180		45	190	250	K2-S12	746	1900	--	--	--	--	--	--

* Weight with oil - ** Bore depth PF=210 - *** Bore depth PF=250

DIMENSIONS ARE NOT BINDING

• Supplied with OVERSIZED CHAMBER SCFM or DCFM

□ Couplings with conical bore FC are supplied with Taper Bush BC and fixing screw (Fig. 1 and 2) - see page 14

Couplings with cylindrical bore D will be supplied until end of stock

In case of mounting on shafts without shoulder contact WESTCAR

Example of order of a coupling with cylindrical bore: ALFA 55 K2 D=60 + S5 G=55x65

Example of order of a coupling with taper bush: ALFA 55 K2 FC + 55BC L15 D=60 + S5 G=55x65

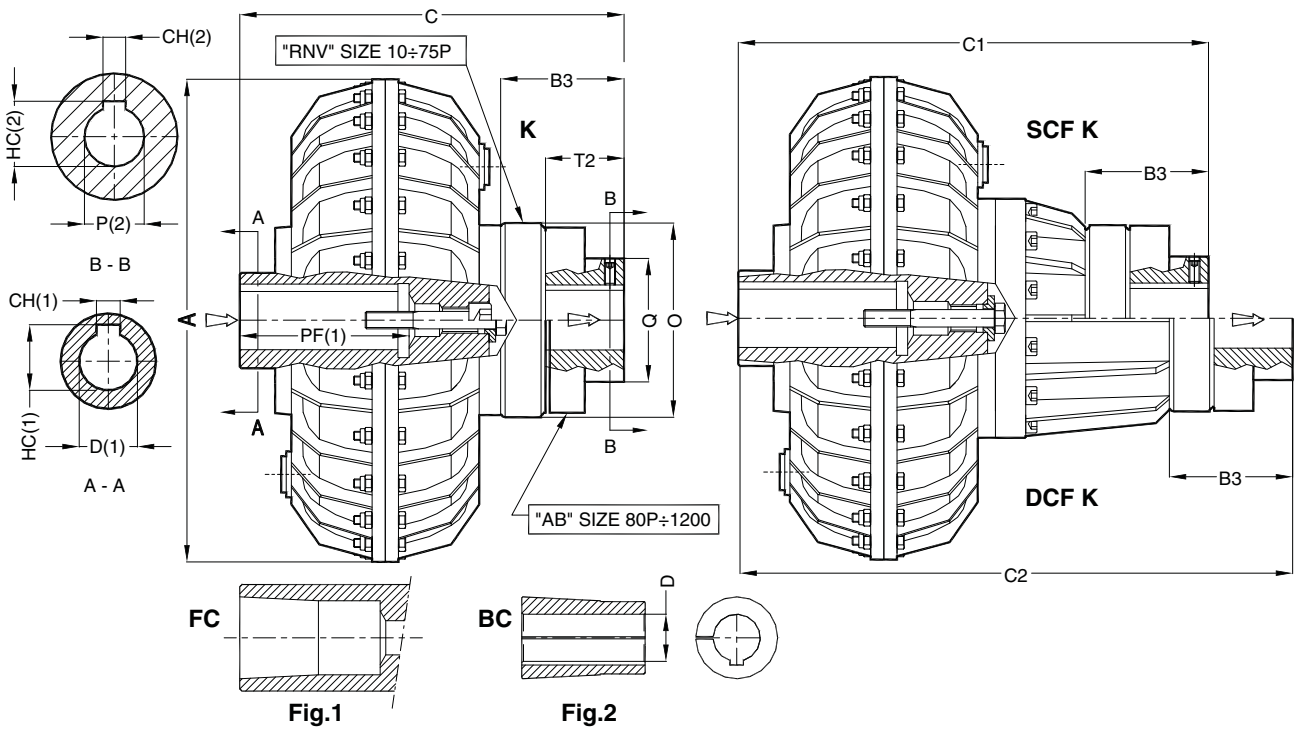

NOTES: (1) for bore and keyway dimensions see sheet 10-019E / (2) upon request: bore P finished / (3) the arrows \Rightarrow indicate input and output

ROTOFLUID GRANDEZZA	Dimensions in mm							K with EL. Coupling		SCF K with EL. Coupling		DCF K with EL. Coupling		ELASTIC COUPLING			
	Bore D	A	B3	O	P Max.	Q	T2	Type	mm	kg*	Type	mm	kg*		Type	mm	kg*
									C	Weight		C1	Weight			C2	Weight
10	19-24	193	48	88	28	45	30	K1	146	4,7	--	--	--	--	--	--	RVN-1
20	24-28	230	67	110	38	56	45	K1	192	7,6	--	--	--	--	--	--	RVN-2
30	38 [□] -42 [□]	290	85	140	48	68	55	K01	247	16,2	K02	302	18,6	K02	342	19,2	RVN-3
30P		327						24		26,4			27				
40P	42 [□] -48 [□]	338	94	176	60	91	60	K01	292	26,6	K02	350	30,3	K02	422	31,8	RVN-4
50	48 [□] -55 [□] -60 [□]	430	108	194	70	106	70	K02	287	37	K02	367	42,8	K02	442	45	RVN-5
55	55 [□] -60 [□] -65 [□]							319	47	K02	399	52,8	K02	474	55		
60	48 [□] -55 [□] -60 [□] 65 [□] -75 [□]	520	122	216	80	121	80	K02	314	56,3	K02	404	64,7	K02	484	68,3	RVN-6
65	48 [□] -55 [□] -60 [□] 65 [□] -75-80							362	76,3	K02	452	84,7	K02	532	88,3		
70P	80-90 100	640	138	266	100	146	90	K2N	378	101,5	K2N	488	114,5	K02	603	121,5	RVN-7
•75P	80-90 100							K3N	418		K3N	528		K3N	643		
	80P	Max.110 Max.125**	640	194	309	110	156	110	K2N	459	154	--	--	--	--	--	FRNV-8
166				--					--	K2M		541	163,7	K2M	656	175,7	RVN-8
•85P	Max.125 Max.130	810	196	330	110	170	140	K2N	466	238,5	K2N	584	254,5	K2N	684	266,5	AB-8
			226					400	155		236	170		K3N	482		
90P	Max.130 Max.140** Max.160***	1000	318	550	180	290	250	K2	682	604	K2	742	556	K2	882	571	AB-9
								K3	782	644	K3	842	596	K3	982	611	
								K5	822	664	K5	882	616	K5	1022	631	
95P	Max.130 Max.140** Max.160***	1000	318	550	180	290	250	K2	797	759	K2	917	799	K2	997	814	AB-9
								K3	904	809	K3	1024	849	K3	1104	864	
								K5	944	829	K5	1064	869	K5	1144	884	
1200	Max. 190	1300	318	550	180	290	250	K2	774	2050	--	--	--	--	--	AB-9/12	

* Weight with oil - ** Bore depth PF=210 - *** Bore depth PF=250

DIMENSIONS ARE NOT BINDING

• Supplied with OVERSIZED CHAMBER SCFM or DCFM

□ Couplings with conical bore FC are supplied with Taper Bush BC and fixing screw (Fig. 1 and 2) - see page 14

Couplings with cylindrical bore D will be supplied until end of stock

In case of mounting on shafts without shoulder contact WESTCAR

Example of order of a coupling with cylindrical bore: ALFA 55 K02 D=60 + RVN5 P=48

Example of order of a coupling with taper bush: ALFA 55 K02 FC + 55BC L15 D=60 + RVN5 P=48

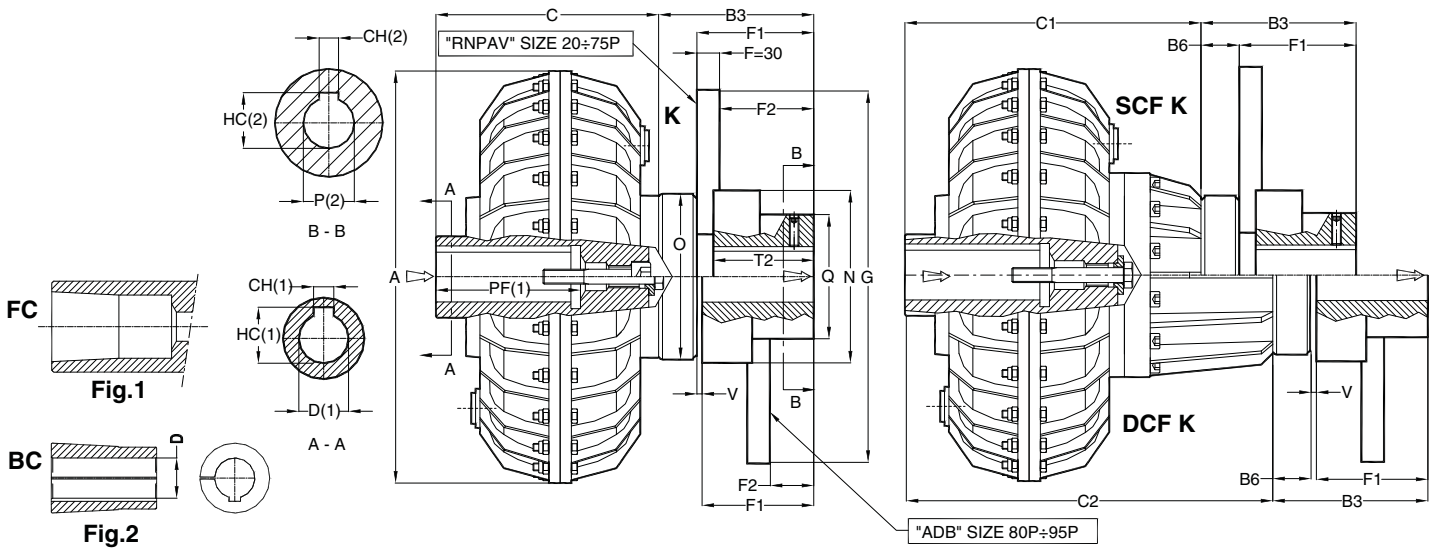

NOTES: (1) for bore and keyway dimensions see sheet 10-019E / (2) upon request: bore P finished / (3) the arrows \rightrightarrows indicate input and output

ROTOFLUID SIZE	Dimensions in mm										K			SCF K			DCF K			ELASTIC ELEMENT WITH BRAKE DISC
	Bore D	A	B3	B6	O	P Max	Q	N	V	Type	mm	kg*	Type	mm	kg*	Type	mm	kg*		
											C	Weight		C1	Weight		C2	Weight		
20	24-28	230	93	22	110	38	56	94	--	K1	125	6	--	--	--	--	--	--	RNPV2	
30	38 [□] -42 [□]	290	111	30	140	48	68	118		K01	162	13,2	K02	217	15,6	K02	257	16,2	RNPV3	
30P		327	123	30	140	48	68	118		K01		21	23,4	K02	257	24	RNPV3			
40P	42 [□] -48 [□]	338	120	34	176	60	91	147		K01	198	22	K02	256	25,7	K02	328	27,2	RNPV4	
50	48 [□] -55 [□] -60 [□]	430	134	38	194	70	106	165		K02	179	30	K02	259	35,8	K02	334	38	RNPV5	
55	55 [□] -60 [□] -65 [□]									K02	211	40	K02	291	45,8	K02	366	48	RNPV5	
60	48 [□] -55 [□] -60 [□] 65 [□] -75 [□]	520	148	42	216	80	121	185		K02	192	46	K02	282	54,4	K02	362	58	RNPV6	
65	48 [□] -55 [□] -60 [□] 65 [□] -75-80									K02	240	66	K02	330	74,4	K02	410	78	RNPV6	
70P	80-90 100	640	164	48	266	100	146	226		K2N	240	86	K2N	350	99	K2N	465	106	RNPV7	
75P	80-90 100									220	84	309	110	156	270	K3N	280	86	K3N	390
	80-90 100	192	--	--	--	--	--	--	--	--						--	--	--	--	--
80P	Max.110 Max.125**	810	196	50	330	110	170	330	K2M	265	117	--	--	--	--	--	--	FRNPV8		
85P	Max.125 Max.130								84	K3M	280	117	K2M	347	135	K2M	462	147	RNPV8	
	90P	Max.130 Max.140** Max.160***	1000	318	62	550	180	290	550	K3M	362	135	K3M	477	147	RNPV8				
80P		270								180	K2N	388	196	K2N	488	208	ADB8			
95P	Max.130 Max.140** Max.160***	1000	318	62	550	180	290	550	K3N	404	196	K3N	504	208	ADB8M					
	85P								300	252	K2N	458	280	K2N	558	300	ADB8M			
95P	Max.130 Max.140** Max.160***	1000	318	62	550	180	290	550	K2	364	350	K2	424	302	K2	504	317	ADB9 ADB9		
									K3	464	390	K3	524	342	K3	604	357			
									K5	504	410	K5	564	362	K5	644	377			
									K2	479	505	K2	599	545	K2	679	560			
									K3	586	555	K3	706	595	K3	786	610			
K5	626	575	K5	746	615	K5	826	630												

* Weight with oil and without Brake Disc RNPV o ADB - ** Bore depth PF=210 - *** Bore depth PF=250

DIMENSIONS ARE NOT BINDING

• Supplied with OVERSIZED CHAMBER SCFM or DCFM

□ Couplings with conical bore FC are supplied with Taper Bush BC and fixing screw (Fig. 1 and 2) - see page 14 - Couplings with cylindrical bore D will be supplied until end of stock

BRAKE DISC RNPV / FRNPV

ROTOFLUID	20	30/30P	40P	50/55	60/65	70P	75P
Brake Disc	RNPV2	RNPV3	RNPV4	RNPV5	RNPV6	RNPV7	FRNPV8
øG	200	200	250 315	250 315 355	315 355 400 450	400 450 500 450 500	560 630 710 800
F1	71	81	86	96	106	116	136
F2	41	51	56	66	76	86	106
T2	45	55	60	70	80	100	110
Weight kg	7,3	8,6	13,7 21,1	16,1 22,6 27,6	25,2 30,1 36,3 43,6	40,5 48,4 57,2 68,6 76,4	88,2 103,5 121,5 146,5

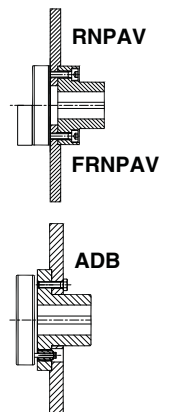

BRAKE DISC ADB

ROTOFLUID	80P					85P					90P/95P				
Brake Disc	ADB8					ADB8M					ADB9				
øG	560	630	710	800	900	630	710	800	900	1000	710	800	900	1000	1250
F1	140					170					250				
F2	50					80					143				
Weight kg	107	122	142	167	234	172	192	215	248	283	325	350	382	417	520

Example of order of a coupling with cylindrical bore: ALFA 55 K02 D=60 + RNPV5 315x30 P=48

Example of order of a coupling with taper bush: ALFA 55 K02 FC + 55BC L15 D=60 + RNPV5 315x30 P=48

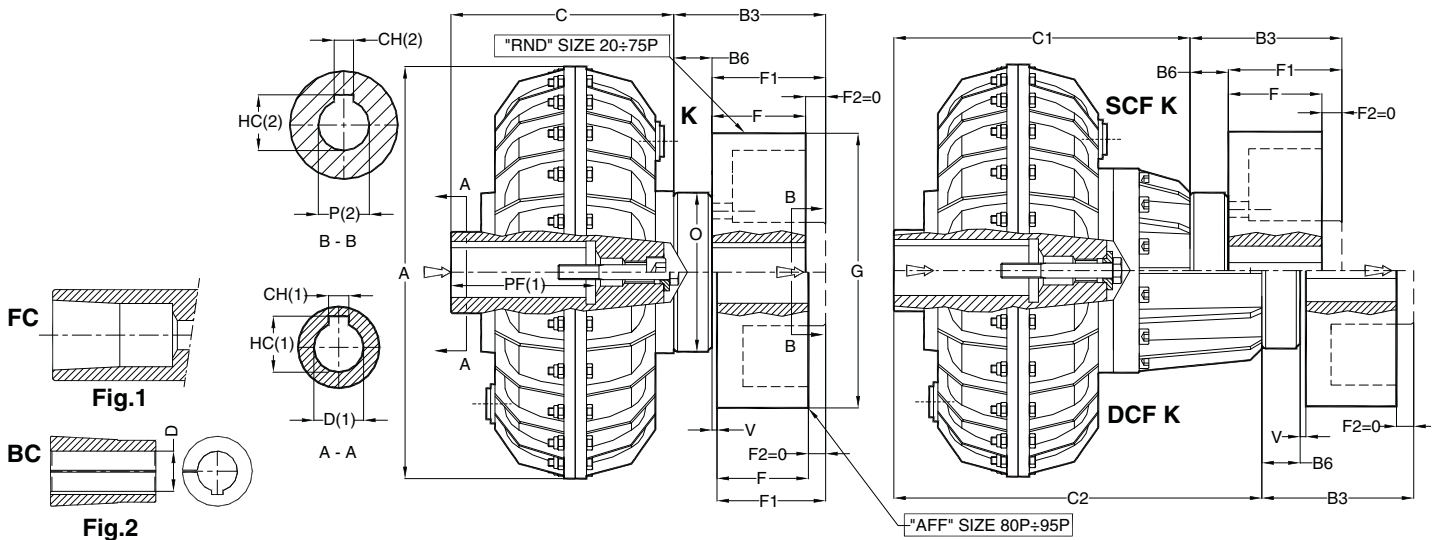

NOTES: (1) for bore and keyway dimensions see sheet 10-019E / (2) upon request: bore P finished / (3) the arrows \triangleright indicate input and output

ROTOFLUID SIZE	Dimensions in mm				K			SCF K			DCF K			ELASTIC ELEMENT WITH BRAKE DRUM		
	Bore D	A	O	V	Type	mm	kg*	Type	mm	kg*	Type	mm	kg*			
30	38 [□] -42 [□]	290	140	--	K01	30	162	13,2	K02	30	217	15,6	K02	30	257	16,2
30P		327			K02				23,4				K02			
40P	42 [□] -48 [□]	338	176	--	K01	34	198	22	K02	34	256	25,7	K02	34	328	27,2
50	48 [□] -55 [□] -60 [□]	430	194		K02				38				179			
55	55 [□] -60 [□] -65 [□]			520	216	K02	42	211		40	K02	42		282	54,4	K02
60	48 [□] -55 [□] -60 [□] 65 [□] -75 [□]	640	266			--			K02		48		240			86
65	48 [□] -55 [□] -60 [□] 65 [□] -75 [□] -80 [□]			640	309		6	K2N	84	265		117		--	--	
70P	80-90 100	810	400			6		K3N			50		280	180		K2N
• 75P	80-90 100			1000	550		6	K2N	62	340		252			K2N	62
80P	Max.110 Max.125**	1000	550			6		K3N			62		364	350	K2	
• 85P	Max.125 Max.130			1000	550		6	K5	62	464		390			K3	62
90P	Max.130 Max.140** Max.160***	1000	550			6		K5			62		504	410	K5	
95P	Max.130 Max.140** Max.160***			1000	550		6	K2	62	479		505			K2	62
		1000	550			6		K3			62		586	555	K3	
				1000	550		6	K5	62	626		575			K5	62

* Weight with oil and without Brake Drum - ** Bore depth PF=210 - *** Bore depth PF=250

DIMENSIONS ARE NOT BINDING

• Supplied with OVERSIZED CHAMBER SCFM or DCFM

□ Couplings with conical bore FC are supplied with Taper Bush BC and fixing screw (Fig. 1 and 2) - see page 14

Couplings with cylindrical bore D will be supplied until end of stock

BRAKE DRUM RND with elastic coupling

ROTOFLUID	30/30P		40P			50/55				60/65				70P				75P-K				75P SCF K/DCF K					
Brake Drum	RND3		RND4			RND5				RND6				RND7				FRND8				RND8					
øG	160	200	250	160	200	250	315	200	250	315	400	200	250	315	400	200	250	315	400	500	315	400	500	315	400	500	
F=F1	60	75	95	60	75	95	118	75	95	118	150	75	95	118	150	118	150	190	118	150	190	118	150	190	118	150	190
B3	90	105	125	94	109	129	152	113	133	156	188	117	137	160	192	166	198	238	202	234	274	174	206	246	206	246	246
P max	48	48	48	60	60	60	60	70	70	70	70	80	80	80	80	100	100	100	110	110	110	110	110	110	110	110	110
Weight kg	4,4	6,6	14	5	7,8	14,6	25,8	8,5	15,6	27,4	46,3	9,6	17,6	30,3	50	31,3	55,8	112	59	82,7	142	46,5	70,2	130	46,5	70,2	130

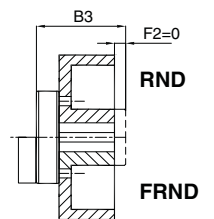

BRAKE DRUM AFF with elastic coupling

ROTOFLUID	80P		85P		90P/95P	
Brake Drum	AFF8		AFF8M		AFF9	
øG	400	500	630	500	630	710
F=F1	150	190	236	190	236	265
B3	206	246	292	246	292	333
P max	110	110	110	160	160	180
Weight kg	105	161	208	193	252	341

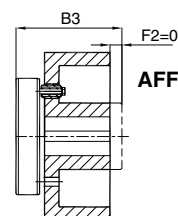

Example of order of a coupling with cylindrical bore: ALFA 55 K02 D=60 + RND5 315x118 P=48

Example of order of a coupling with taper bush: ALFA 55 K02 FC + 55BC L15 D=60 + RND5 315x118 P=48

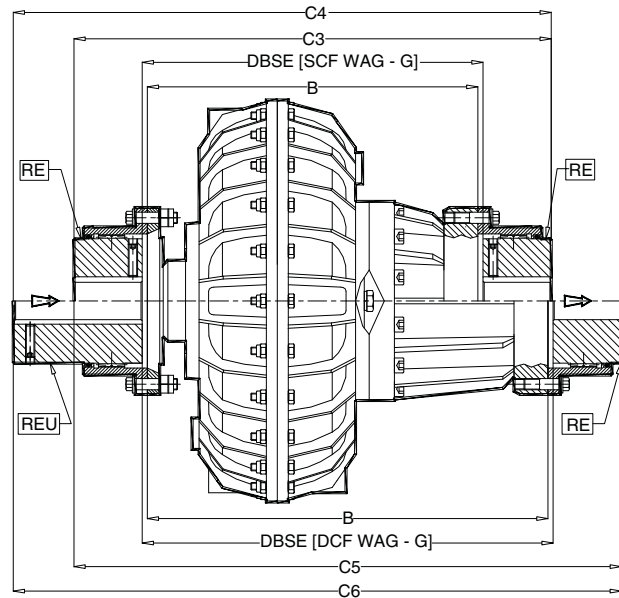
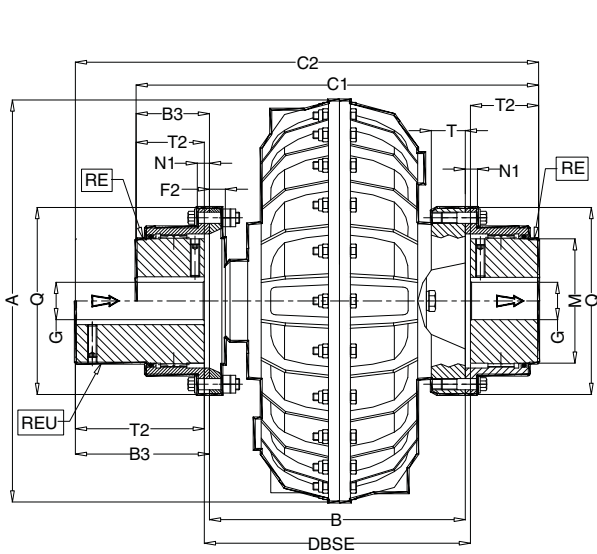

NOTES: (1) upon request: bore G finished / (2) the arrows \rightarrow indicate input and output / (3) reverse mounting is possible upon request

ROTOFLUID SIZE	Dimensions in mm										WAG-G					WAG-GU							
											GEAR COUPLING	Dimensions in mm				kg*	GEAR COUPLING	Dimensions in mm				kg*	
	A	B	F2	B3	M	N1	Weight	T	DBSE	C1		G		B3	T2	Weight		C2	G		B3	T2	Weight
20	230	162	14	44,5	69	12	111	23	165	RE40	251	10	45	44,5	43	13	RE40U	313	10	45	106,5	105	15
30	290	197	12	51,5	85	10	142	23	200	RE55	300	18	60	51,5	50	26,5	RE55U	365	18	60	116,5	115	29,5
30P	327																						
40P	338	233	23	92,5	152	13	225	60,5	236	RE100	336	50	110	92,5	90	34,5	RE100U	401	50	110	172,5	170	39,5
50	430	214																					
55	430	256,5	28	78,5	133	13	200	55,5	217	RE85	413,5	40	95	78,5	76	79,3	RE85U	487,5	40	95	152,2	150	85
60	430	265																					
65	520	313	28	108	178	22	265	72	318	RE120	422	60	130	108	105	107,2	RE120U	544	60	130	188	185	92
70P	520	313																					
75P	640	293,5	34	154	254	24	370	42	298,5	RE180	478,5	95	190	154	150	146,7	RE180U	558,5	95	190	299	295	156
80P	640	348,5																					
85P	810	370	50	194	305	25	438	49	376	RE220	533,5	120	230	194	190	187,5	RE220U	613,5	120	230	309	305	224,5
90P	810	440																					
95P	1000	555	90	305	25	438	49	520	448	RE250	863	120	230	194	190	2200	RE250U	1008	120	230	309	305	224,5
1200/2	1300	512																					

ROTOFLUID SIZE	Dimensions in mm		SCF						Dimensions in mm		DCF					
			WAG-G			WAG-GU					WAG-G			WAG-GU		
	B	DBSE	GEAR COUPLING	mm	kg*	GEAR COUPLING	mm	kg*	B	DBSE	GEAR COUPLING	mm	kg*	GEAR COUPLING	mm	kg*
30	252	255	RE55	355	28,5	RE55U	420	31	292	295	RE55	395	29,5	RE55U	460	31,5
30P																
40P	291	294	RE55	394	40	RE55U	459	43	363	366	RE55	466	41	RE55U	531	44
50	294	297														
55	336,5	341,5	RE85	493,5	85	RE85U	567,5	91	411,5	416,5	RE85	568,5	87	RE85U	642,5	93
60	355	360														
65	403	408	RE100	588,5	160	RE100U	668,5	169	518,5	523,5	RE100	703,5	166,5	RE100U	783,5	179
70P	403,5	408,5														
•75P	458,5	463,5	RE120	704	278	RE120U	784	280,5	588	594	RE120	804	290	RE120U	884	302,5
80P	488	494														
•85P	558	564	RE180	808	542	RE180U	953	587	580	588	RE180	888	557	RE180U	1033	602
90P	500	508														
95P	675	683														

* Weight with oil

DIMENSIONS ARE NOT BINDING

• Supplied with OVERSIZED CHAMBER SCFM or DCFM

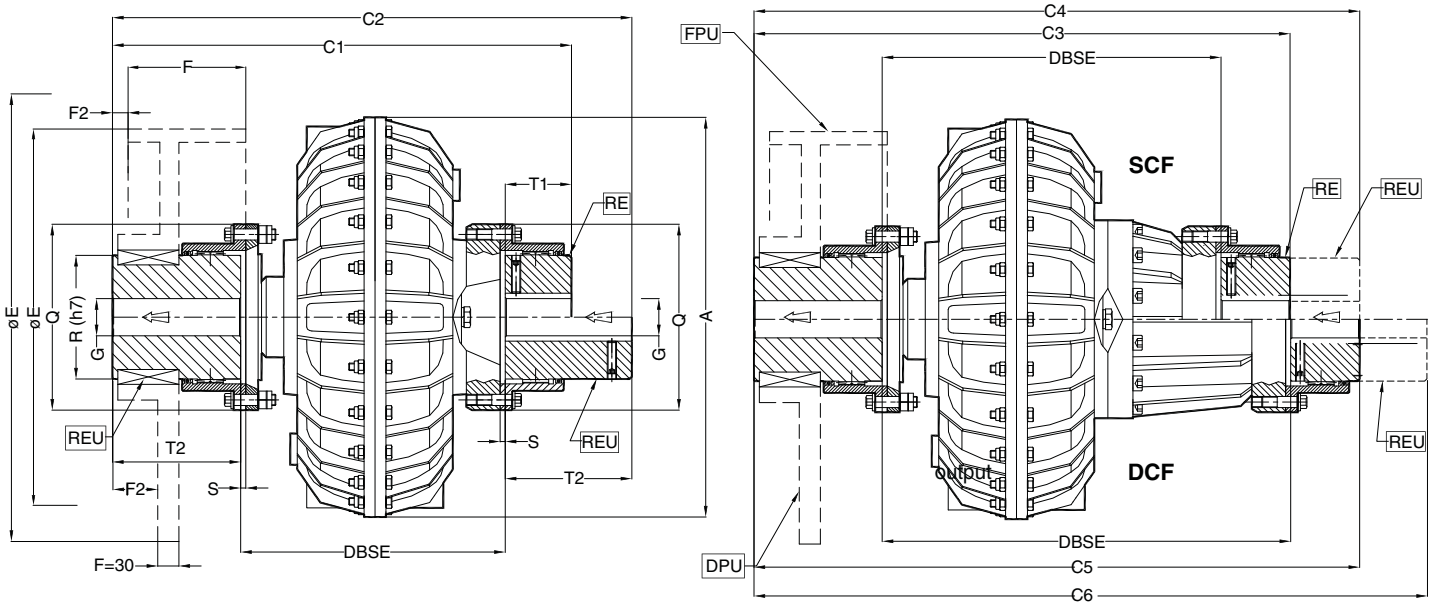

NOTES: (1) upon request: bore G finished / (2) the arrows \rightarrow indicate input and output

ROTOFLUID SIZE	GEAR COUPLINGS		Dimensions in mm								SCF					DCF									
	Standard Hub	Long Hub	A	G min	G max	Q	R (h7)	S	T2 RE	T2 RE U	WAG-GPU		WAG-GPUU		WAG-GPU		WAG-GPUU		WAG-GPU		WAG-GPUU				
											mm	mm	kg*	mm	kg*	mm	mm	kg*	mm	mm	kg*	mm	mm	kg*	mm
30	RE55	RE55U	290	18	60	142	80	1,5	50	115	DBSE	C1	W.	C2	W.	DBSE	C3	W.	C4	W.	DBSE	C5	W.	C6	W.
30P			200								365	28,9	430	31,3	255	420	485	33,3	295	460	31,9	525	34,3		
40P			236								401	38,6	466	41	294	459	42,4	524	44,8	366	531	43,4	596	45,8	
50			217								382	46,6	447	49	297	462	52	527	54,5	372	537	54,4	602	56,8	
55	RE85	RE85U	430	40	95	200	125	2,5	76	150	261,5	487,5	85,3	561,5	91	341,5	567,5	91	641,5	97	416,5	642,5	93	716,5	99
60			270								496	92	570	98	360	586	101	660	107	440	666	104	740	110	
65			318								544	113	618	119	408	634	122	708	128	488	714	125	788	131	
70P	RE100	RE100U	640	50	110	225	145	2,5	90	170	298,5	558,5	156	638,5	165	408,5	668,5	169	748,5	178	523,5	783,5	176	863,5	185
•75P			353,5								613,5	196	693,5	206	463,5	723,5	210	803,5	219	578,5	838,5	217	918,5	226	
80P	RE120	RE120U	810	60	130	265	175	3	105	185	376	666	275	746	287	494	784	291	864	303	594	884	303	964	315
•85P			416								736	378	816	399	534	854	428	934	449	634	954	447	1034	469	
90P	RE180	RE180U	1000	95	190	370	245	4	150	295	448	893	595	1038	640	508	953	587	1098	632	588	1033	602	1178	647
95P			563								1008	755	1153	800	683	1128	795	1273	840	763	1208	810	1353	855	
1200	RE220	RE220U	1300	120	230	438	290	5	190	305	520	900	2200	1015	2245	UPON REQUEST					UPON REQUEST				

* Weight with oil • Supplied with OVERSIZED CHAMBER SCFM or DCFM

Example of order with standard hub: ALFA 80P SCF WAG-G RE120PU [RM] G(m)= 100 G(r)=90

Example of order with long hub: ALFA 80P SCF WAG-G RE120PUU [RM] G(m)= 100 G(r)=90

BRAKE DRUM FPU

ROTOFLUID	30-30P-40P-50				55-60-65				70P-75P			80P-85P			90P-95P			1200		
Type FPU	FPU-55				FPU-85				FPU-100			FPU-120			FPU-180			FPU-220		
Ø E	160	200	250	315	400	250	315	400	315	400	500	400	500	630	500	630	710	630	710	800
F	60	75	95	118	150	95	118	150	118	150	190	150	190	236	190	236	265	236	265	300
F2	UPON REQUEST																			
Z	0	0	0	3	35	0	0	0	0	0	20	0	5	51	0	0	0	0	0	0
Weight kg	5,4	9,2	14,5	29	50,8	19,5	30,8	52,8	35,9	58,3	96,8	57	95,6	134	105	142	178	145	180	254

BRAKE DISC DPU

ROTOFLUID	30-30P-40P-50				55-60-65				70P-75P			80P-85P			90P-95P			1200								
Type DPU	DPU-55				DPU-85				DPU-100			DPU-120			DPU-180			DPU-220								
Ø E	250	315	355	400	355	400	450	500	500	560	630	710	500	560	630	710	800	1000	710	800	1000	1250	800	1000	1250	
F2	41	41	41	41	45	45	45	45	60	60	60	60	60	60	60	60	60	60	105	105	105	105	UPON REQUEST			
Weight kg	11,7	18,5	23,5	28,8	25,2	31,5	38,5	47,3	51	63	78	98	50	61,6	77	97	122	188	105	130	197	300				

DIMENSIONS ARE NOT BINDING

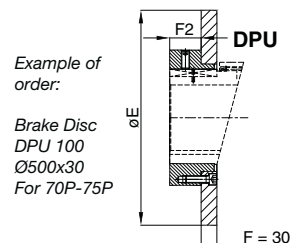
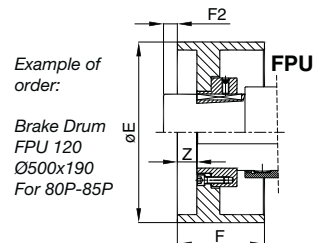

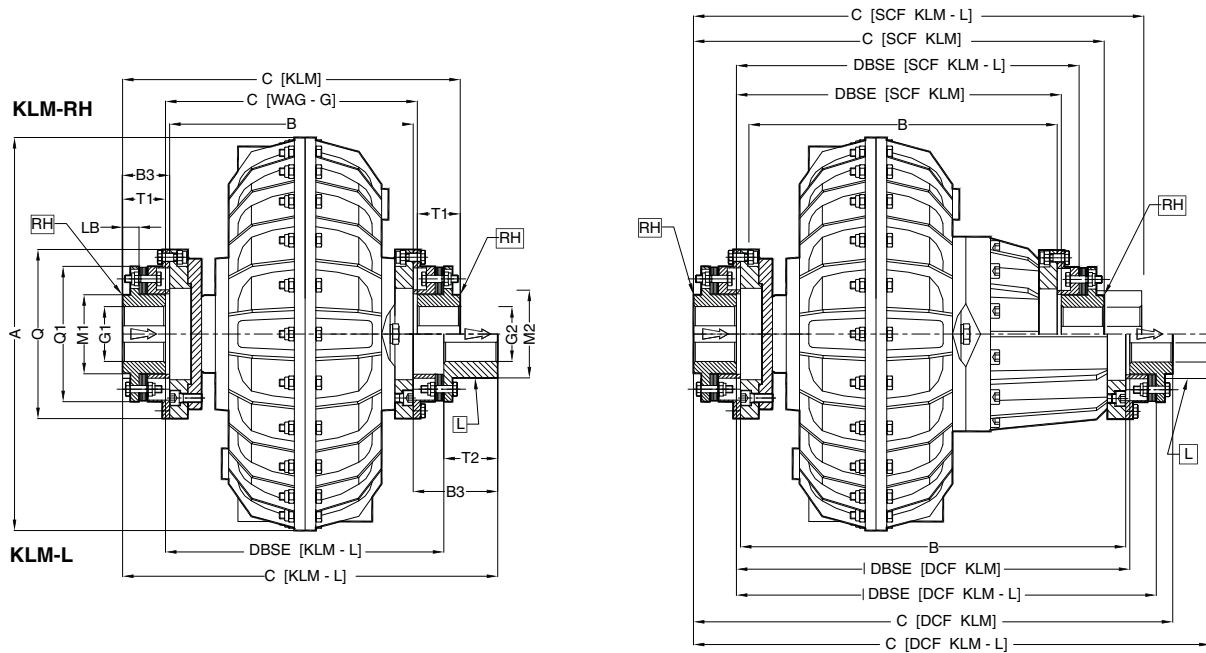

NOTES: (1) upon request: bore G finished / (2) the arrows \rightrightarrows indicate input and output / (3) reverse mounting is possible upon request

ROTOFLUID SIZE	DISC COUPLING HBSX	KLM-RH											KLM-L									
		Dimensions in mm											kg*	Dimensions in mm								kg*
		A	B	C	G1 max	DBSE	B3	LB	M1	Q	Q1	T1	Weight	C	G2 max	DBSE	B3	M2	T2	Weight		
30	170	290	214	303	48	217	44,5	16,3	64	155	119	43	26,4	346,7	55	243,7	88,2	75	60	27,2		
30P		327	250	339		253							34,2			243,7					35	
40P		338	250	339		253							37			382,7					279,7	37,8
50	330	430	234	337	65	237	51,5	18	86	185	148	50	51,6	389	65	269	103,5	92	70	52,9		
55		266	369	269		61,6							421			301				62,9		
60	650	520	256	383	85	259	63,5	25	120	260	214	62	94,5	468	95	296	148,5	135	110	101,5		
65		304	431	307		114,5							516			344				121,5		
70P	1260	640	276	433	100	281	78,5	28	138	295	246	76	161	525	110	329	170,5	155	120	169,4		
75P		331	488	336		192							580			384				200,4		
80P	2700	810	360	576	105	366	108	35	150	330	275	105	322	666	120	436	198	165	125	328,9		
85P	3160		606	125	123		41	175	365	308	120	357	710	135	445	227	190	145	366,7			
90P	3160	1000	430	676	125	436	123	41	175	365	308	120	429	780	135	515	227	190	145	438,7		
95P	4630		461	707	125	467	123	41	175	365	308	120	530	811	135	546	227	190	145	545,3		
95P	4630	576	854	140	584	139	46	195	415	346	135	740	973	150	673	258	215	165	755,3			
1200		UPON REQUEST																				

* Weight with oil

DIMENSIONS ARE NOT BINDING

ROTOFLUID SIZE	DISC COUPLING HBSX	SCF KLM-RH				SCF KLM-L				ROTOFLUID SIZE	DISC COUPLING HBSX	DCF KLM-RH				DCF KLM-L					
		mm				kg*						mm				kg*					
		B	DBSE	C1	T1	Weight	DBSE	C1	T2			Weight	B	DBSE	C2	T1	Weight	DBSE	C2	T2	Weight
30	170	269	272	358	43	28,8	298,7	401,7	60	29,6	170	309	312	398	43	29,4	338,7	441,7	60	30,2	
30P		36,6	37,4	38,2																	
40P		308	311	397		41,4				337,7		440,7	42,2	40P		380				383	469
50	330	314	317	417	50	57,4	349	469	70	58,7	330	389	392	492	50	59,6	424	544	70	60,9	
55		346	349	449		67,4	381	501		68,7		55	421	424		524	69,6	456		576	70,9
60	650	346	349	473	62	102,9	386	558	110	109,9	650	426	429	553	62	106,5	466	638	110	113,8	
65		394	397	521		122,9	434	606		129,9		65	474	477		601	126,5	514		686	133,5
70P	1260	386	391	543	76	174	439	635	120	182,4	1260	501	506	658	76	181	554	750	120	189,4	
•75P		441	446	598		205	494	690		213,4		•75P	556	561		713	212	609		805	220,4
80P	2700	478	484	694	105	338	554	784	125	344,9	2700	578	584	794	105	350	654	884	125	356,9	
85P	3160	478	484	724	120	373	563	828	145	382,7		3160	648	654	894	120	477	733	998	145	486,7
•85P	3160	548	554	794	120	457	633	898	145	466,7	•85P	648	654	894	120	477	733	998	145	486,7	
90P	3160	521	527	767	120	482	606	871	145	497,3	90P	4630	601	607	847	135	497	686	951	145	512,3
95P	4630	696	704	974	135	780	793	1093	165	795,3	95P	4630	776	784	1054	135	795	873	1173	165	810,3

• Supplied with OVERSIZED CHAMBER SCFM or DCFM

Example of order : ALFA 55KLM-L 330 RH (with 1 RH hub and 1 L hub)

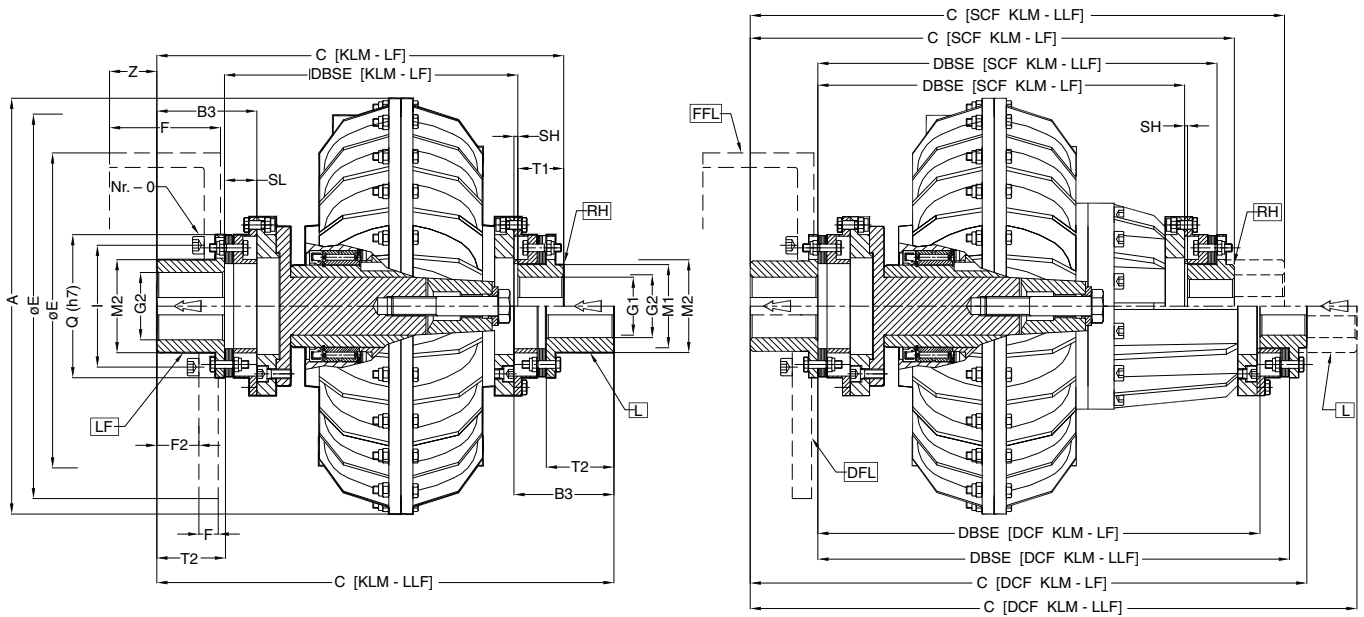

NOTES: (1) upon request: bore G finished / (2) the arrows \rightrightarrows indicate input and output

ROTOFLUID SIZE	DISC COUPLING HBSX	mm																										
		KLM								SCF KLM				DCF KLM														
		LF		LLF		LF		LLF		LF		LLF		LF		LLF												
A	B3	OG1 max	OG2 max	SH	SL	M2	Qh7	DBSE	C	T1	W	DBSE	C	T2	W	DBSE	C	W	DBSE	C	W	DBSE	C	W				
30		290							243,7	346,7	43	27,2	270,4	390,4	60	28	298,7	401,7	29,6	325,4	445,4	30,4	338,7	441,7	30,2	365,4	485,4	31
30P	170	327	88,2	48	55	1,5	28,2	75	118,5			35				35,8			37,4			38,2						39
40P		338							279,7	382,7	43	37,8	306,4	426,4	60	38,6	337,7	440,7	42,2	364,4	484,4	43	409,7	512,7	43	436,4	556,4	43,8
50		430							269	389		52,9	301	441		54,2	349	469	58,7	381	521	60	424	544	60,9	456	596	62,2
55	330	430	103,5	65	65	1,5	33,5	92	147,5			62,9	333	473		64,2	381	501	68,7	413	553	70	456	576	70,9	488	628	72,2
60		520							296	468		101,5	333	553		108,5	386	558	109,9	423	643	116,9	466	638	113,8	503	723	123
65	650	520	148,5	85	95	1,5	38,5	135	213			121,5	381	601		128,5	434	606	129,9	471	691	136,9	514	686	133,5	551	771	140,5
70P		640							329	525		169,4	377	617		177,8	439	635	182,4	487	727	190,8	554	750	189,4	602	842	197,8
75P	1260	640	170,5	100	110	2,5	50,5	155	245			200,4	432	672		208,8	494	690	213,4	542	782	221,8	609	805	220,4	657	897	228,8
80P	2700	810	198	105	120	3	73	165	274			328,9	506	756		335,8	554	784	344,9	624	874	351,8	654	884	356,9	724	974	363,8
85P	3160	810	227	125	135	3	82	190	307			366,7	524	814		377,4	563	828	382,7	642	932	392,4	663	928	394,7	742	1032	404,4
90P	3160	1000	227	125	135	3	82	190	307			438,7	594	884		448,4	633	898	466,7	712	1002	476,4	733	998	486,7	812	1102	496,4
95P	4630	1000	258	140	150	4	93	215	346			545,3	625	915		560,6	606	871	497,3	685	975	512,6	686	951	512,3	765	1055	527,6
1200		UPON REQUEST																										

* Weight with oil

DIMENSIONS ARE NOT BINDING

BRAKE DRUM FFL

ROTOFLUID	30-30P-40P				50-55				60-65				70P-75P				80P		85P-90P		95P	
FFL	FFL 170				FFL 330				FFL 650				FFL 1260				FFL 2700		FFL 3160		FFL 4630	
Ø E	160	200	250	315	200	250	315	400	250	315	400	315	400	500	400	500	500	630	630	630	710	
F	60	75	95	118	75	95	118	150	95	118	150	118	150	190	150	190	190	236	236	236	265	
F2	0	-	-	-	-	-	-	-	15	-	-	2	-	-	-	-	-	-	-	-	-	
Z	0	15	35	58	5	25	48	80	-	8	40	-	30	70	25	65	45	91	71	100		
I	100				128				195				224				216		282		314	
Nr.-Ø	8 M10				8 M12				16 M12				16 M14				8 M20		16 M20		16 M20	
Weight kg	4	6,8	11,5	28	6,5	11,1	27,7	49,1	9,9	25	47,5	24	46	85	46,1	84,7	83,3	121	119	154,8		

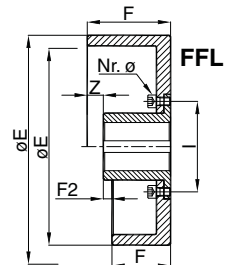

BRAKE DISC DFL

ROTOFLUID	30-30P-40P				50-55				60-65				70P-75P				80P		85P-90P		95P					
DFL	DFL 170				DFL 330				DFL 650				DFL 1260				DFL 2700		DFL 3160		DFL 4630					
Ø E	250	315	355	315	355	400	450	400	450	500	500	560	630	710	800	500	630	710	800	630	710	800	710	800	1000	1250
F	30			30			30				30				30				30							30
F2	27,5			34,5			70				79				81				96							113
I	100				128				195				224				216		282		314					
Nr.-Ø	8 M10				8 M12				16 M12				16 M14				8 M20		16 M20		16 M20					
Weight kg	10,5	17	22,3	16	21,8	28	35,9	26,2	34	42,8	41,7	53,5	70	88,8	114	41,2	53	68,4	88,2	66,7	86,5	112	84,7	109,8	176,3	280,3

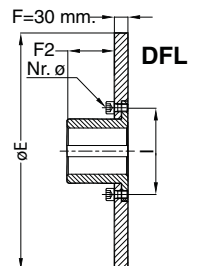

* Supplied with OVERSIZED CHAMBER SCFM or DCFM

Example of order: ALFA 55 SCF KLM 330 LF [RM] G(m)=60 G(r)=40 with Brake Drum FFL 330 ØE 315x118

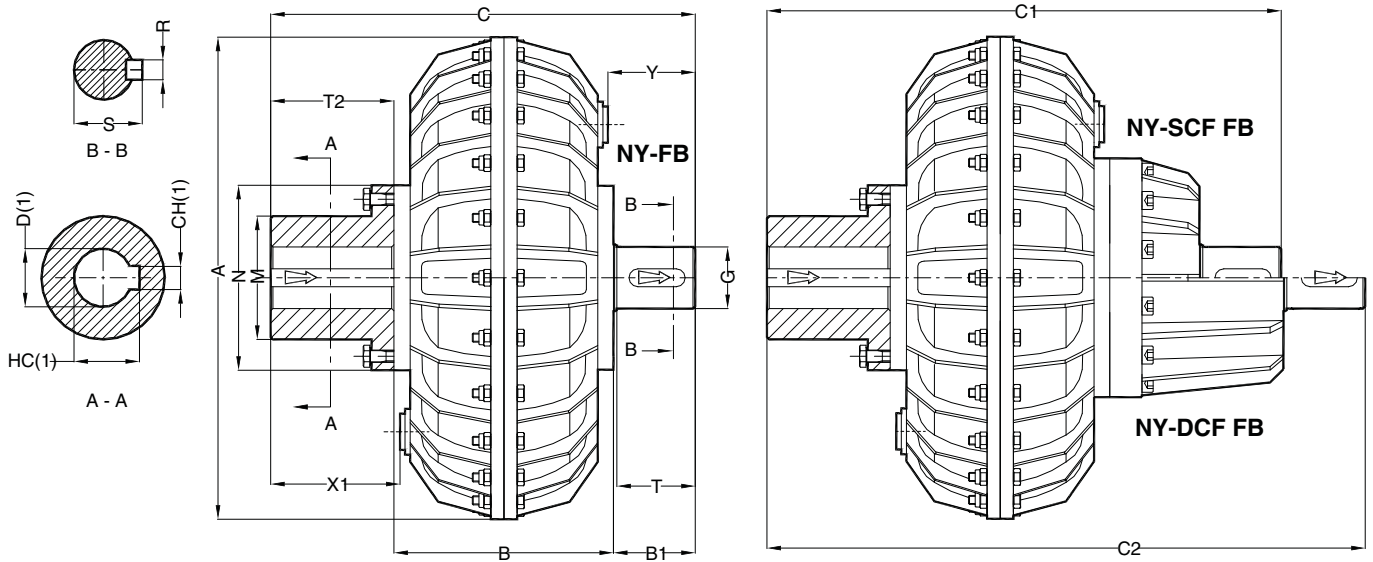

NOTES: (1) for bore and keyway dimensions see sheet 10-019E / (2) the arrows \Rightarrow indicate input and output

ROTOFLUID SIZE	NY-FB														NY-SCF FB		NY-DCF FB		
	Dimensions in mm														kg*	mm	kg*	mm	kg*
	D ⁶⁷	A	B	B1	C	G ^{h7}	N	M	R	S	T	T2	X1	Y	Weight	C1	Weight	C2	Weight
30	28	290	150	51	261	38	116	80	10	41	45	60	69	55	18	316	20,5	356	21,1
	38														21,5		22,1		
	42-48-55														22,5		23,1		
30P	28	327	150	51	261	38	116	80	10	41	45	60	64	55	27	316	29,5	356	30,1
	38														30,5		31,1		
	42-48-55														31,5		32,1		
40P	38	338	183	61	324	48	145	91	14	51,5	55	80	104	72	31	382	35	454	37
	42-48-55														32		36		38
50	42-48-55	430	154	71	325	55	165	110	16	59	65	100	106	91	44	405	50	480	52
	60-65-75														46		52		54
55	42-48-55	430	196	71	367	55	165	110	16	59	65	100	106	77	54	447	60	522	62
	60-65-75														56		62		64
60	48-55	520	172	86	368	60	185	135	18	64	80	110	116	106	67	458	75	538	79
	60-65-75														71		79		83
65	55	520	220	86	416	60	185	135	18	64	80	110	116	92	87	506	95	586	99
	60-65-75														91		99		103
70P	65-75	640	190	96	426	70	225	160	20	74,5	90	140	140	111	124	536	137	651	144
	80-90														129		142		149
•75P	65-75	640	245	96	481	70	225	160	20	74,5	90	140	140	96	165	591	178	706	185
	80-90														170		183		190
80P	60-65-75	810	226	116	482	80	270	170	22	85	110	140	140	131	232	600	248	700	260
	80-90														238		254		266
•85P	60-65-75	810	300	116	556	80	270	170	22	85	110	140	140	116	304	674	332	774	352
	80-90														310		338		358
90P	80-90-95	1000	344	186	700	110	345	250	28	116	180	170	170	240	460	760	500	840	520
	100-110														470		510		530
90P	120-140	1000	344	186	700	110	345	250	28	116	180	170	170	240	480	760	520	840	540

* Weight with oil

DIMENSIONS ARE NOT BINDING

● Supplied with OVERSIZED CHAMBER SCFM or DCFM

Example of order: ALFA 55 NY-FB D=65
ALFA 55 NY-SCF FB D=65
ALFA 55 NY-DCF FB D=65

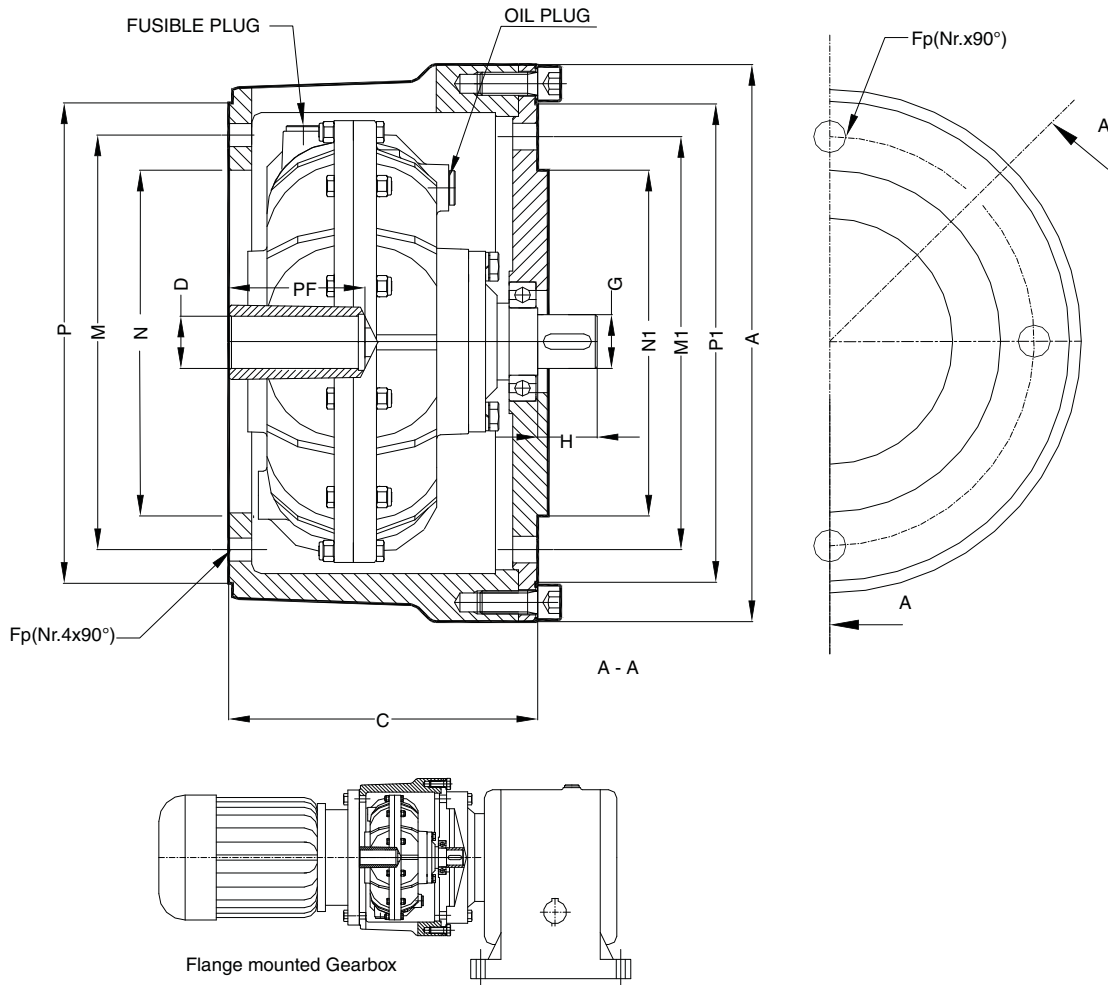

COUPLING		MOTOR		Dimensions in mm												kg*	
SIZE	Type	Type	kW	A	C	D ^{G7}	Fp	G ^{h7}	H	M	M1	N ^{f7}	N1 ^{h7}	P	P1	PF	Weight
10	CKS-19-19	80	0,55	240	128	19	ø11	19	25	165	165	130	130	200	200	40	8,5
			0,75					24								24	
	CKS-24-24	90 S	1,1					24								24	
90 L		1,5	24	24	50												
20	CKS-28-28	100	2,2	292	161	28	ø13	28	32	215	215	180	180	250	250	60	24
			3					28									
30	CKS-38-38	132S 132M	5,5	350	210	38	ø13	38	45	265	265	230	230	300	300	80	36,5
			7,5					38									
30P	CKS-42-42	160 M 160 L	11	400	210	42	ø17	42	300	300	250	250	350	350	110	40	
			15					42									350
40P	CKS-48-48	180 M 180 L	18,5	400	255	48	ø17	48	55	300	300	250	250	350	350	110	42
			22					48									

* Weight with oil

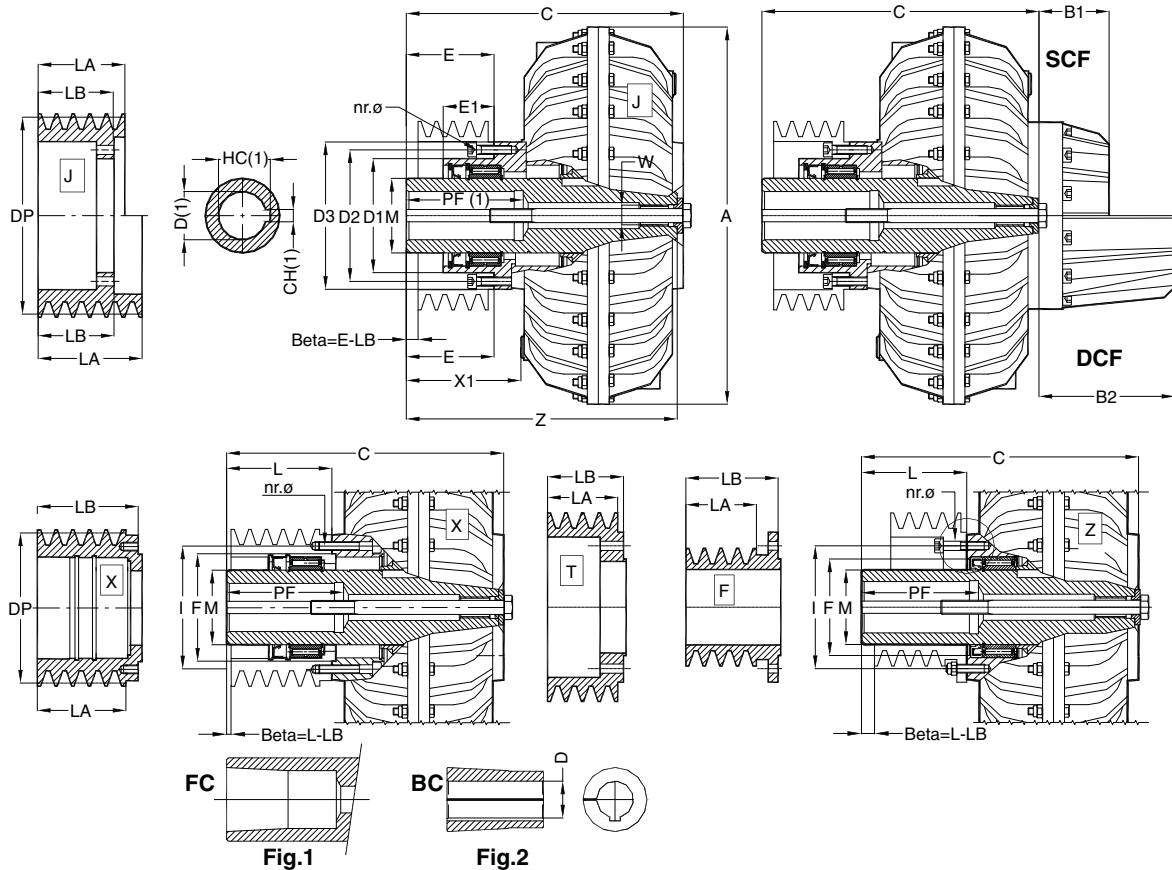

NOTES: (1) for bore and keyway dimensions see sheet 10-019E / 2) for the choice of the assembly coupling-pulley, LA - LB quotes, see WESTCAR Pulley
(3) X couplings are supplied with X type pulleys for pitch diameters less than the minimum diameters of the J type pulleys

ROTOFLUID SIZE	Type	Dimensions in mm															J		X / Z		SCF		DCF	
		Bore D	A	C	D1 ^{H7}	D2	D3	E	E1	F ^{H7}	I	L	M	Nr.-Ø	X1	Z	W	Weight kg*	Weight kg*	B1	Weight kg*	B2	Weight kg*	
10	Z 55	24	192	143	-	-	-	-	47	60	55	40	6-M6	57	140	M10	-	4,2	-	-	-	-		
20	Z 70	28	229	185	-	-	-	-	62	78	70	45	6-M8	76	180	M14	-	6,5	-	-	-	-		
30	J / X / Z 88	38 [□] -42 [□]	290	238	85	100	114	70	45	75	100	88	60	8-M8	97	233,5	M24	16,3	14,8	55	2,4	95	3	
30P	J / X / Z 88	38 [□] -42 [□]	327															24,3	22,8					
40P	J / X / Z 90	42 [□] -48 [□]	338	273	112	130	145	89	60	100	125	90	80	8-M8	114	268	M24	28	25	58	4	130	5	
	J / X / Z 118			301				117				118						142	296					29
50	J / X 90	48 [□] -55 [□] -60 [□]	430	244	130	150	170	70	58	110	140	90	85	8-M10	95	241,5	M24	33	31	80	6	155	8	
	J / X 120			274				100				110						120	85					125
55	J / X 155	55 [□] -60 [□] -65 [□]	520	351	150	170	184	135	88	125	160	155	110	8-M10	160	348,5	M30	46	43	90	8,4	170	12	
60	J / X 130	55 [□] -60 [□] -65 [□] 75-80		302				110				130			135	302		60	55					
	J / X 170		342	150	170	110	170	74	69															
65	J / X 130	55 [□] -60 [□] -65 [□] 75-80	520	350	150	170	184	110	88	125	160	130	110	8-M10	135	302	M30	62	57	90	8,4	170	12	
	J / X 170			390				150				170			175	390		77	72					
70P	J / X 170	80	640	380	188	210	230	140	100	150	195	170	120**	8-M14	169	369	M36	120,5	111	110	13	225	20	
	J / X 210			80-90-100**				420				170			210	180		209	409					123,5
•75P	J / X 210	80-90-100**	810	470	214	240	270	180	130	190	230	210	140	8-M18	209	459	M36	156,5	147	118	16	218	28	
80P	J / X 255A	80-90-100		481				170				210			254	475		222,5	207					28
•85P	J / X 255A	80-90-100	810	555	214	240	270	225	130	190	230	255	140	8-M18	254	549	M36	303,5	290	118	16	218	28	
		80-90-100		555				225				255			254	549		303,5	290					

* Weight with oil - ** For D=100 M = 135 mm - *** Bore depth PF=250

DIMENSIONS ARE NOT BINDING

• Supplied with OVERSIZED CHAMBER SCFM or DCFM

□ Couplings with conical bore FC are supplied with Taper Bush BC and fixing screw (Fig. 1 and 2)

■ Taper Bushes are supplied without keyway

Couplings with cylindrical bore D will be supplied until end of stock

In case of mounting on shafts without shoulder contact WESTCAR

Example of order of a coupling with cylindrical bore: BETA 55 J155 D=60

Example of order of a coupling for taper bush: BETA 55 J155 FC

Example of order of a coupling with taper bush: BETA 55 J155 FC + 55BC L155 D=60

TAPER BUSH BC WITH FIXING SCREW				
COUPLING SIZE	Type	Standard D Bore		Max D Bore
30/30P	3BC	38	42	48
40P	4BC	42	48	50
50	5BC	48	55	65
55	5BC	55	60	65
60	6BC	55	60	70
65	6BC	55	60	70

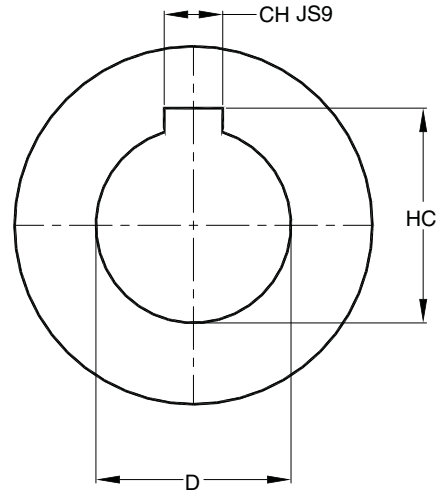
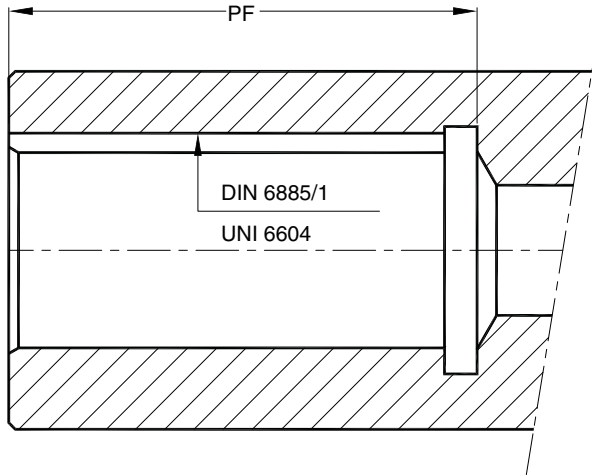

D	Tolerance	PF	CH	HC	Tolerance	
10	H7	25	3	11,4	+ 0,1	
11 *		25	4	12,8		
12		25	4	13,8		
13		30	5	15,3		0
14 *			5	16,3		
15			5	17,3		
16		40	5	18,3	+0,2	
17			5	19,3		
18			6	20,8		
19 *			6	21,8		
20			6	22,8		
21			50	6		23,8
22		6		24,8		
23		8		26,3		
24 *		8		27,3		
25		8		28,3		
26		8		29,3		
27		60	8	30,3	+0,2	
28 *	8		31,3			
30	8		33,3			
32	10		35,3			
33	G7	80	10	36,3	0	
34			10	37,3		
35			10	38,3		
38 *			10	41,3		

D	Tolerance	PF	CH	HC	Tolerance		
40	G7	110	12	43,3	+0,2		
42 *			12	45,3			
45			14	48,8			
48 *			14	51,8			
50			14	53,8			
55 *			16	59,3			
60 *		140	18	64,4		0	
65 *			18	69,4			
70 *			20	74,9			
75 *		20	79,9				
80 *		170	22	85,4			+0,2
85 *			22	90,4			
90 *	25		95,4				
95	25	100,4					
100 *	210	28	106,4	0			
105		28	111,4				
110 *		28	116,4				
115	250	32	122,4		0		
120		32	127,4				
125 *		32	132,4				
130		32	137,4				
135 *		36	143,4				
140		36	148,4				
160	40	169,4					
180	45	190,4					

* STANDARD BORES FOR UNEL MEC ELECTRIC MOTORS

FUSIBLE PLUG TF

In case of overheating, the fusible plug allows the oil out and thereby disconnects the power transmitted to the output shaft. Fusible plugs are available for four different melting temperatures: 96°C, 120°C, 145°C and 180°C. WESTCAR standard couplings are supplied with fusible plug at 145° C.

THERMAL SWITCHING PIN TE

In case of coupling overheating with a thermal switching pin, a pin is released and collide against a limit switch which activates an alarm or shuts off the electric motor. This method avoids the oil leakage from the coupling. Fusible switching pins are available for four different temperatures: 96°C, 120°C, 145°C and 180°C. In case of stall conditions, motor running and machine locked, the coupling housing must be driving to guarantee the signal survey.

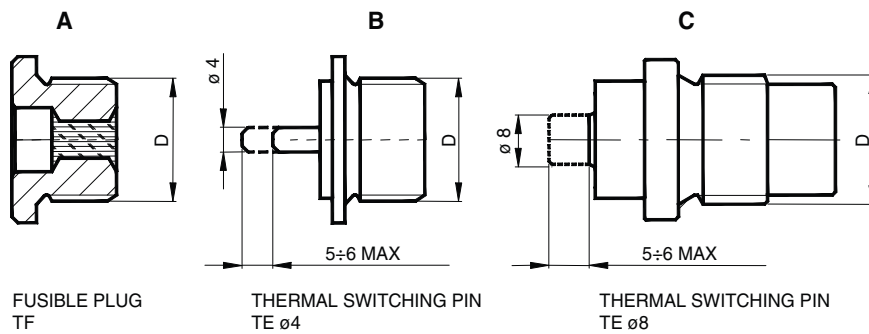

ROTOFLUID SIZE	DIMENSIONS				TEMPERATURE			
	D	A	B	C	96 °C BLUE	120 °C WHITE	145 °C RED	180 °C GREEN
10 20 30-30P 40P	1/4 GAS	X	X	-	•	•	•	•
50-55 60-65	1/2 GAS	X	X	-	•	•	•	•
70P-75P 80P-85P	1/2 GAS	X	-	X	•	•	•	•
90P-95P	3/4 GAS	X	-	X	•	•	•	•

When ordering specify: dimension D, safety plug melting temperature and colour.
Example of order: **Thermal switching pin TE ¼ GAS 145°C RED.**

THERMAL SWITCHING PIN STANDARD POSITION

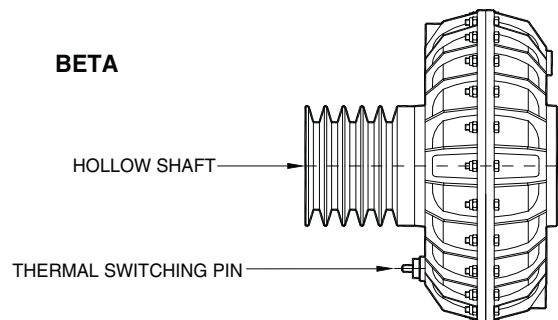
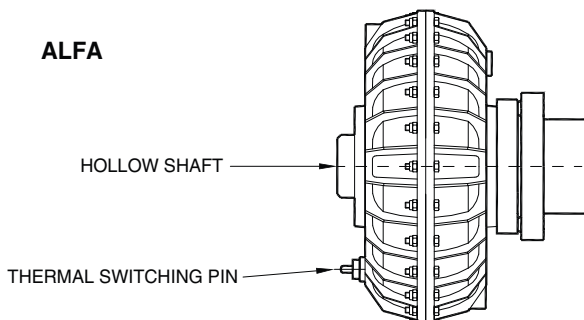

The thermal switching pin is normally mounted by the hollow shaft side but in case of need can be located in the opposite side.

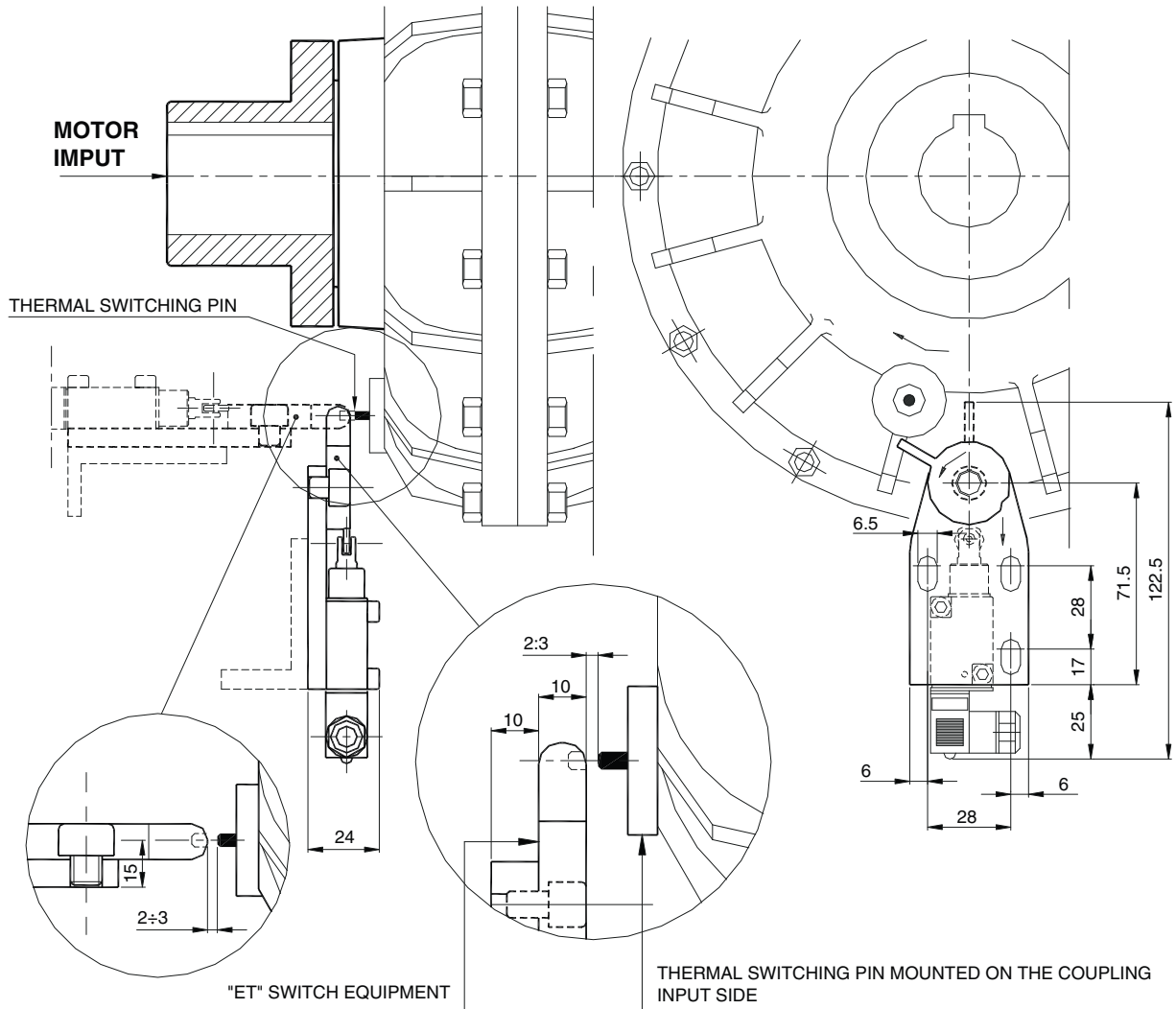

"ET" CONNECTED TO A LIGHT SOUND SIGNAL

"ET" CONNECTED TO SWITCH OFF THE DRIVE

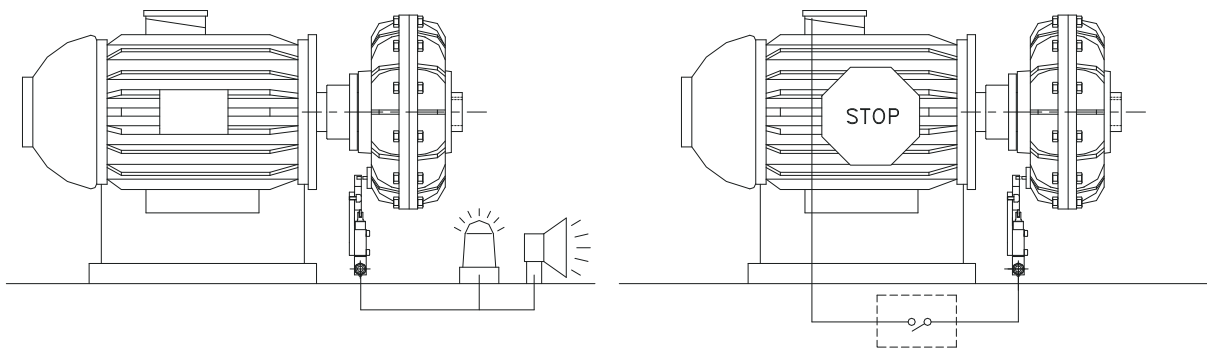

The ET safety device consists of a microswitch and a cam mounted on a base and operates in combination with a thermal switching pin fitted on the fluid coupling housing. In case of coupling overheating due to overloads and machine jams or reduced oil filling, the oil temperature can exceed the melting temperature set for the thermal switching pin. The pin then extends and makes contact with the cam of the microswitch sounding an alarm or shutting down the drive.

- A** Rotofluid Coupling
- B** LOGIC
- C** PLUG "PM" no contact
- D** Sensor SE

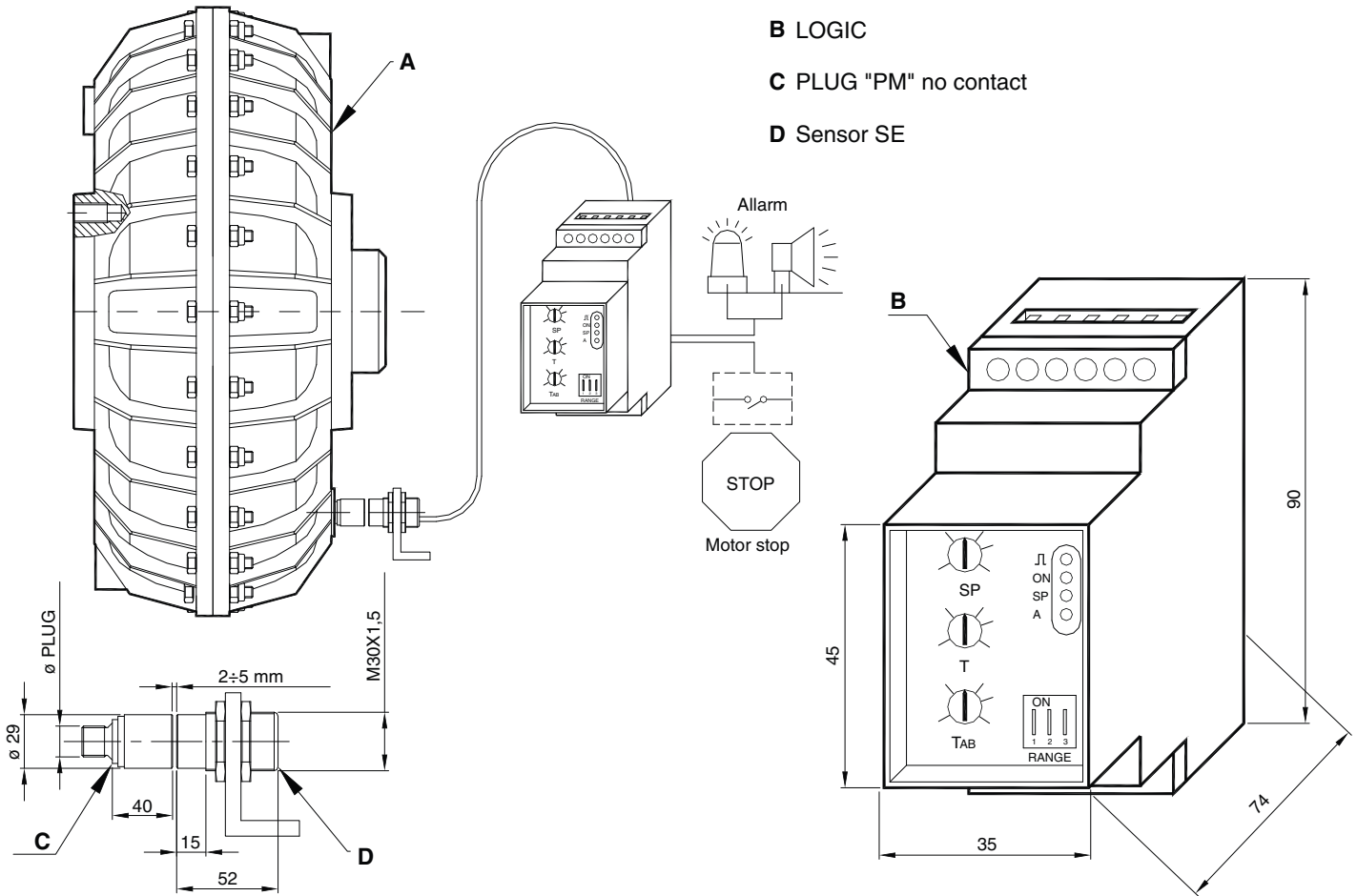

DEVICE T09 WITH PM

The Plug PM is fitted on the outer impeller, in contact with the oil inside the coupling.
 The outer wheel of the coupling (A) can be connected to the machine (driven side) or connected to the motor (drive side).
 If the Plug PM is mounted on the driven side the system detects the variation of temperature and speed. If it is mounted on the drive side the system detects only the temperature.

WORKING PRINCIPLE

The Plug PM contains a thermal element that changes its status at the temperature of 120°C (or upon request: 80°C, 100°C, 140°C or 160°C).
 The plug PM, Normally Closed, crossing the SE sensor acts as a pulse generator, consequently the SE sensor sends impulses to the device LOGICA T09.

Once the temperature limit is reached the thermal element opens and the plug PM and the sensor SE no longer generate impulses. The device LOGICA T09 not receiving more signals, will switch the inner relay, providing an alarm signal or stopping the motor.

POWER SUPPLY: Standard tension 24Vac (upon request: 115 Vac, 230 Vac or 24Vdc).

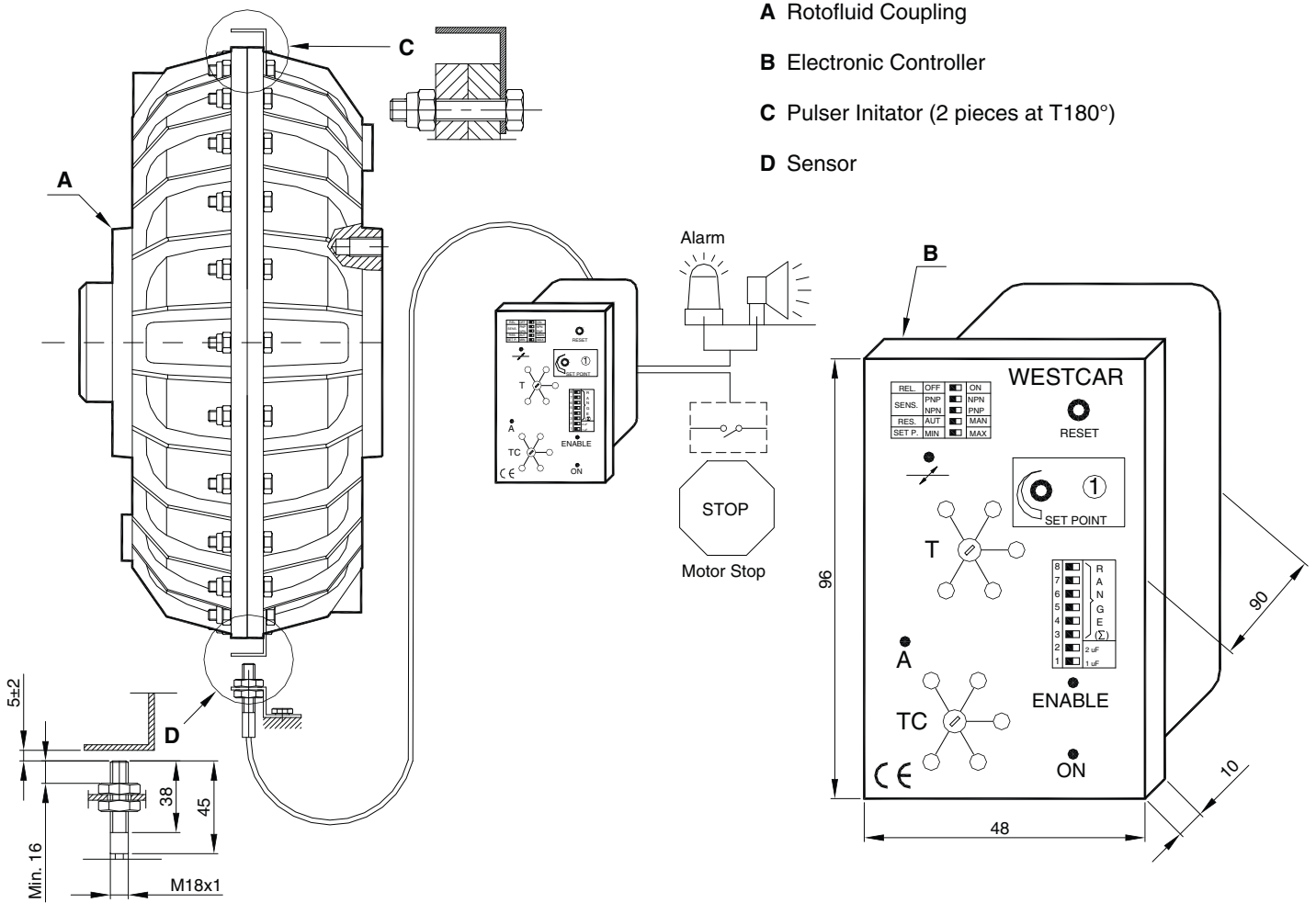

DEVICE SCD

The **SCD** Device can be applied to guarantee the safety of coupling the machine and the product quality.

The **SCD** device is an electronic controller which receives a train of pulses by a sensor. The pulses are converted into a proportional voltage to the pulses frequency. This voltage is compared with a variable reference voltage (SET POINT). The internal relay changes over when the input speed is faster or lower than the fixed (SET POINT). It is used to control the shaft revolution speed. In case of speed decrease, the device gives a signal to the operator.

WORKING PRINCIPLE

As the transmitted torque is increased, this gives rise to an increased slip of the fluid coupling. Possible overload can be detected by measuring the resulting speed reduction in the driven half coupling by means of overload **SCD**. This with change-over contact at the output may either emit an alarm signal or switch off the main motor. A delaying action (max 120 sec) prevents the unnecessary triggering of the relay, when the motor is started. It only occurs once when the operating voltage is applied. False alarms are prevented arising from very short torque fluctuations, by the introduction of a preset time lag (max 30 seconds).

POWER SUPPLY: Standard tension 24 Vac (upon request: 115 Vac, 230 Vac or 24 Vdc).

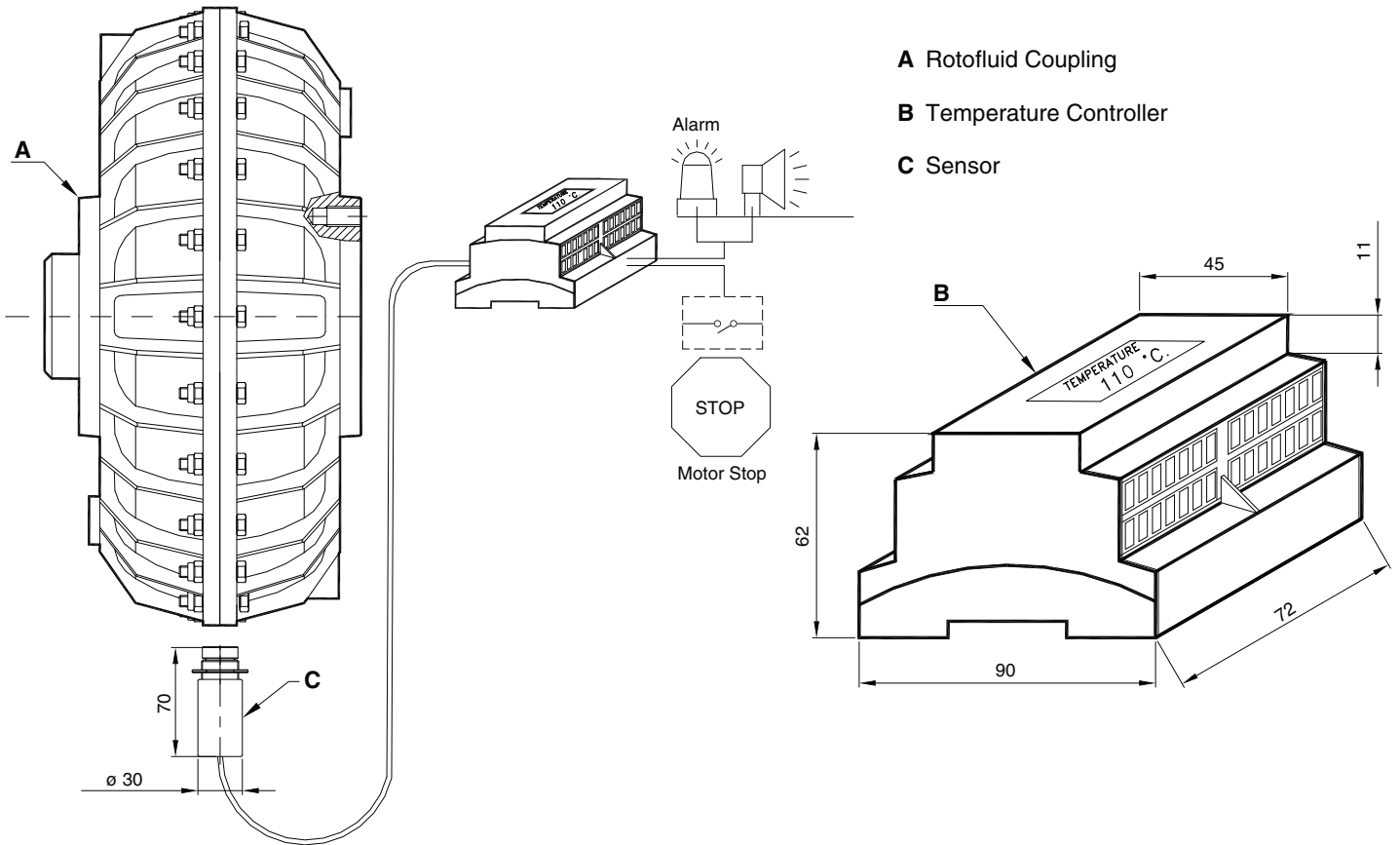

The **continuous monitoring** of the components substantially contributes to preserve the performance of a system itself, while assuring, in the meantime, a considerable **increase in reliability**.

The **ITC (Infrared Temperature Controller)** infrared device allows the monitoring of the fluid coupling temperature, contactless, in real time and in a temperature range between -20°C and $+250^{\circ}\text{C}$, thus providing the ability to regulate workloads or possible intervention. This is an advantage which increases the effectiveness of the whole system and reduces downtime.

Moreover, through the **sensor control interface**, integrated in the DIN rail mounted control system, it is possible to **set two limit temperatures** (Low and High level) to get a signal when such temperatures are reached.

Finally, **if the integration of the device in existing control systems is desired**, ITC is able to provide the current temperature value through a 0-10 V analog output, which can be useful for data transmission to other equipment or for automatic setup of the monitored system parameters.

ITC Device Characteristics
Continuous monitoring
Real time temperature acquisition
Current temperature visualization on the LCD display
2 programmable digital output – limit temperatures
Evaluation of temperature gradient
Easy and quick installation with standard DIN rail mount
Wide spectrum of application
0-10 V analog output

SCREW PULLER "VE" TYPE

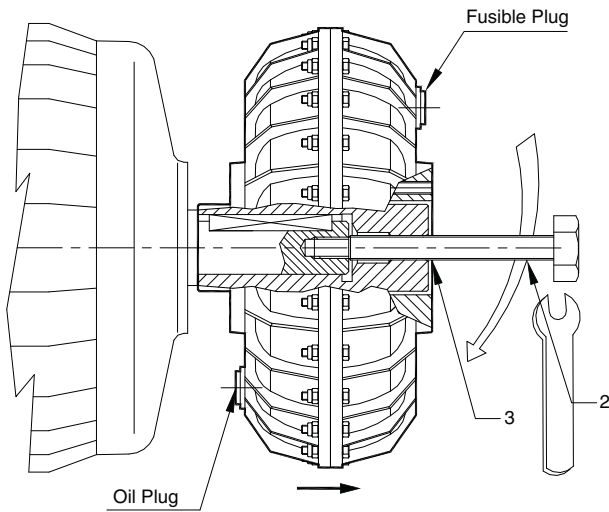

VE SYSTEM	ROTOFLUID COUPLING					
	SIZE	VERSIONS				
Type		K	Z	J	H	X
VE M14	20	K1	Z70	J70	H55	XN70
VE M16		K3	Z69	-	-	-
VE M20				J103	H85	X103
VE M24	30	ALL VERSIONS				
	30P					
	40P					
	50					
VE M30	55	UP TO Ø 65				
	55	FOR Ø75 Ø 80				
VE M36	60	ALL VERSIONS				
	65					
	70P					
	75P					
	80P					
	85P					
	90P					
95P						

To pull off the ROTOFLUID coupling proceed as follows:

- 1) Remove tightening screw
- 2) Tighten the screw (2) into the threaded hole of the coupling shaft (3), taking care to lock the rotation of the drive shaft.

PULLING OFF SYSTEM "SE" TYPE

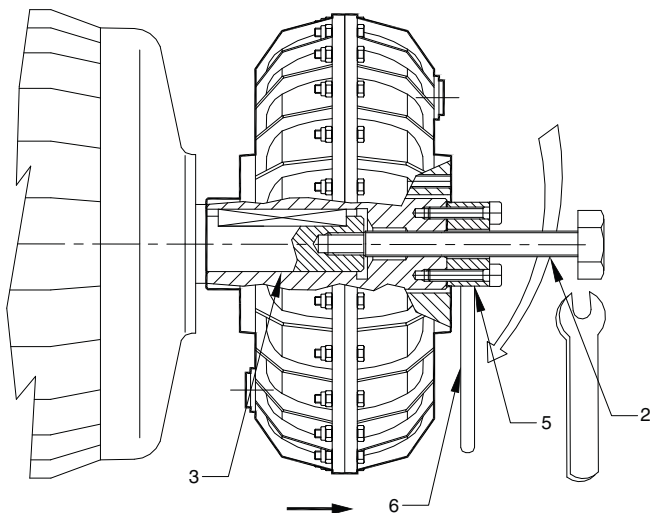

SE SYSTEM	ROTOFLUID COUPLING					
	SIZE	VERSIONS				
Type		K	Z	J	H	X
SE M20	20	-	-	J 103	H 85	X 103
SE M24/35	30	ALL VERSIONS				
SE M24/40	30P					
	40P					
SE M30	50	UP TO Ø 65				
	55	FOR Ø75 Ø 80				
SE M36	60	ALL VERSIONS				
	65					
	70P					
	75P					
	80P					
	85P					
	90P					
95P						

To pull off the ROTOFLUID coupling proceed as follows:

- 1) Remove tightening screw
- 2) Lock the bush (5) to the shaft end (3) with 2 securing screws. Tight the screw puller (2) in the shaft threaded hole keeping locked the rod (6) to avoid the motor shaft rotation.

The mass moment of inertia values listed in the table below are referred to inner part, outer part and oil where:

- **INNER PART** = hollow shaft, impeller pump, half oil
- **OUTER PART** = turbine and cover housing, half oil

Values valid for ROTOFLUID couplings with oil level at 45° off center pulleys, flexible couplings and other accessories are not included.

For couplings with delay fill chamber SCF/DCF, add their values to the correspondent of the outer part of the couplings.

INNER PART	OUTER PART	INNER PART	OUTER PART	DELAY CHAMBER
SIZES: 10, 20, 30, 30P, 40P, 50, 60, 70P, 80P, 90P		SIZES: 55, 65, 75P, 85P, 95P		

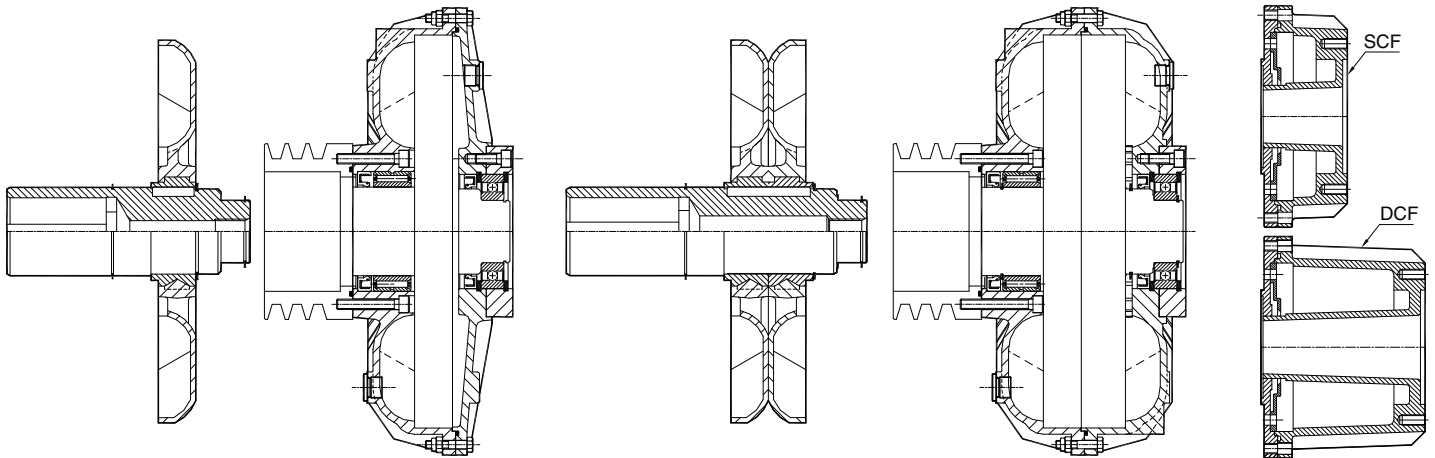

MOMENT OF INERTIA $J = \frac{m \times R^2}{2}$ (Kgm²)

ROTOFLUID COUPLING SIZE	ALFA VERSION		BETA VERSION				DELAY CHAMBER			
	Tipo K		Tipo Z, X		Tipo J		Tipo H		SCF	DCF
	J INNER kgm ²	J OUTER kgm ²	J INNER kgm ²	J OUTER kgm ²	J INNER kgm ²	J OUTER kgm ²	J INNER kgm ²	J OUTER kgm ²	J kgm ²	J kgm ²
10	0,003	0,011	0,003	0,011	--	--	0,003	0,012	--	--
20	0,006	0,024	0,006	0,024	0,006	0,026	0,006	0,027	--	--
30	0,021	0,081	0,022	0,081	0,022	0,084	0,022	0,086	0,006	0,007
30P	0,040	0,140	0,045	0,140	0,045	0,144	0,045	0,147	0,006	0,007
40P	0,060	0,179	0,065	0,179	0,065	0,190	0,065	0,197	0,013	0,016
50	0,105	0,363	0,109	0,363	0,109	0,376	0,109	0,385	0,026	0,032
55	0,208	0,474	0,214	0,474	0,214	0,487	0,214	0,496	0,026	0,032
60	0,311	0,795	0,326	0,795	0,326	0,823	0,326	0,842	0,053	0,062
65	0,564	1,040	0,583	1,040	0,583	1,068	0,583	1,087	0,053	0,062
70P	0,678	2,386	0,740	2,386	0,740	2,473	0,740	2,551	0,160	0,200
75P	1,236	2,782	1,260	2,782	1,260	2,869	1,260	2,947	• 0,350	• 0,550
80P	2,389	7,276	2,499	7,276	2,499	7,393	--	--	0,350	0,550
85P	4,668	9,977	4,792	9,977	4,792	10,094	--	--	• 0,900	• 1,400
90P	8,372	23,200	--	--	--	--	--	--	1,200	1,600
95P	15,613	28,855	--	--	--	--	--	--	1,200	1,600
1200	54,000	260,000	--	--	--	--	--	--	--	--
1200D	104,000	320,000	--	--	--	--	--	--	--	--

• OVERSIZED CHAMBER SCFM / DCFM

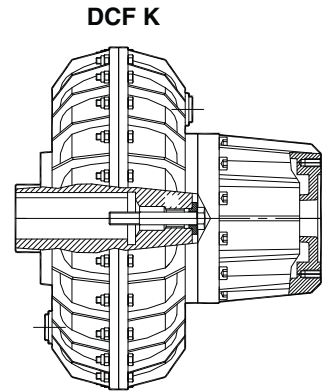
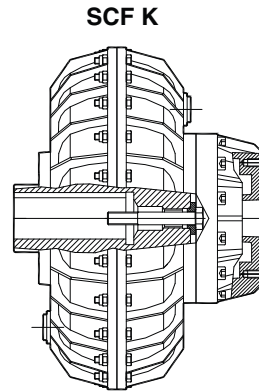
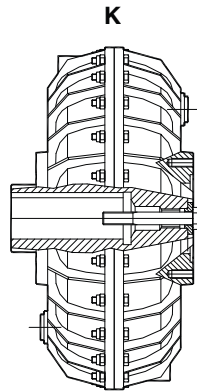
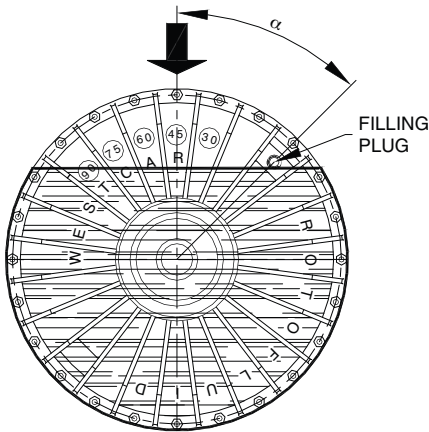

OIL REPLACEMENT

The oil in the coupling must be changed for the first time after 2000 working hours and subsequently after each 4000 working hours. To change the oil, proceed as follows:

- 1) Rotate the coupling to bring the filling plug to its highest position
- 2) Unscrew and remove the filling plug
- 3) Determine the correct filling level by rotating the coupling until the filling hole corresponds to the current oil level
- 4) Completely drain the oil in the coupling by bringing the filling hole to its lowest point
- 5) Rotate the coupling again to bring the filling hole to correspond to the filling level determined at point 3
- 6) Pour in the new oil until the oil filling level is reached.

The quantity and type of oil recommended is listed in Table 1.

Results achieved by **decreasing the oil quantity**:

- Slower and more gradual startings
- Less absorption of startings current
- Better protection to the transmission elements in the event of overload
- Higher slip value at running.

IMPORTANT:

An excessive decrease in the oil quantity can cause the following problems:

- The impossibility of rapidly accelerating the machine due to insufficient torque.
- The overheating of the coupling, with consequent damage to the oil seals.

Results achieved by **increasing the oil quantity**:

- Faster startings
- Lower slip value at running
- Higher absorption of starting current during acceleration phases
- Greater strain on transmission elements.

IMPORTANT:

An excessive oil quantity can cause the following problems:

- The overloading of the electric motor
- The cracking of the coupling housing due to the internal overpressure caused by the lack of internal space for sufficient oil expansion

TYPES OF OIL RECOMMENDED FOR STANDARD WORKING TEMPERATURE

Working Temperature from -20°C to +180°C

- BP ENERGOL HPL 22÷32
- CASTROL HYPIN AWS 22÷32
- ESSO SPINESSO 22÷32
- MOBIL VELOCITE OIL D
- Q8 VERDI 22÷32
- SHELL MORLINA 22÷32

Tab. 1

COUPLING SIZE	OIL QUANTITY FOR STANDARD FILLING					
	K		SCF K		DCF K	
	α	Liter	α	Liter	α	Liter
10	45°	0,55	--	--	--	--
20	45°	1,20	--	--	--	--
30	45°	2,39	55°	2,43	65°	2,42
30P	45°	4,05	55°	3,94	65°	3,78
40P	45°	4,07	55°	4,06	70°	4,09
50	45°	4,39	65°	4,37	75°	4,59
55	45°	7,19	60°	7,04	70°	7,17
60	45°	8,61	65°	8,23	75°	8,41
65	45°	13,48	60°	12,80	70°	12,77
70P	45°	18,05	65°	16,89	75°	17,64
•75P	45°	30,14	65°	29,36	75°	29,68
80P	45°	35,53	65°	35,21	75°	35,27
•85P	45°	60,64	65°	57,79	75°	56,28
90P	45°	91,92	60°	81,70	70°	90,62
95P	45°	153,3	60°	154,9	70°	146,7
1200	45°	200	--	--	--	--
1200D	45°	400	--	--	--	--

• OVERSIZED CHAMBERS SCFM, DCFM

For more information, consult WESTCAR.

Do not exceed Quantity of oil indicated in Table 1.

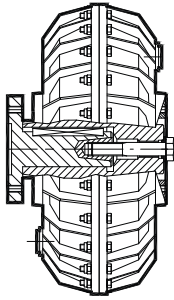

Fig. 1

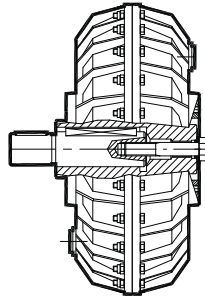

Fig. 2

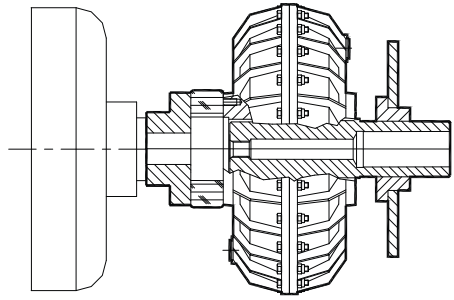

Fig. 3

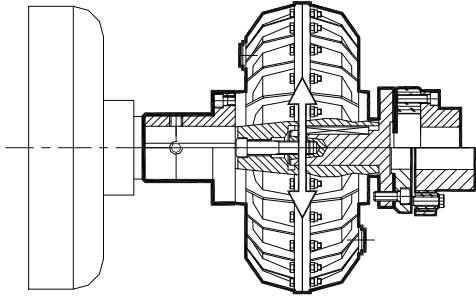

Fig. 4

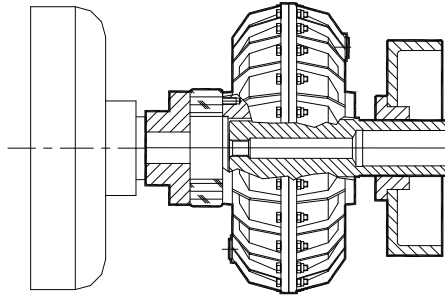

Fig. 5

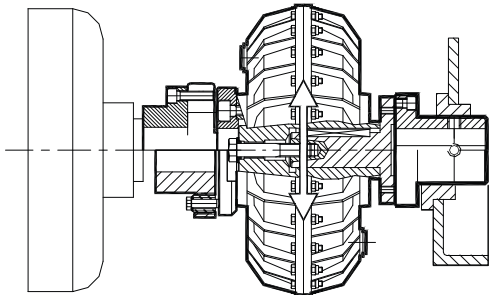

Fig. 6

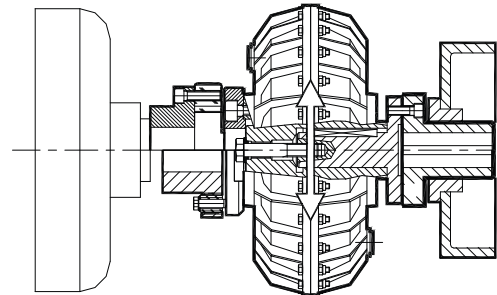

Fig. 7

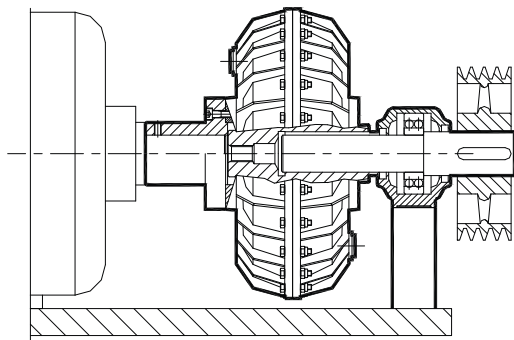

Fig. 8

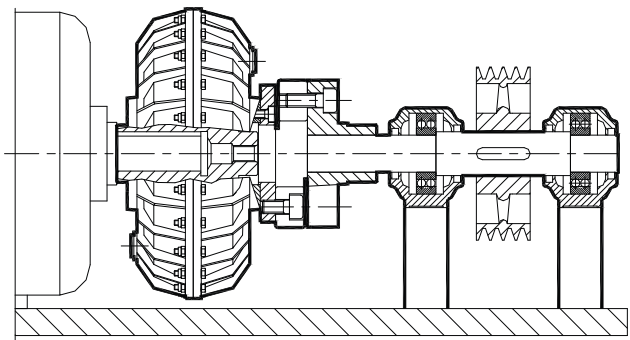

Fig. 9

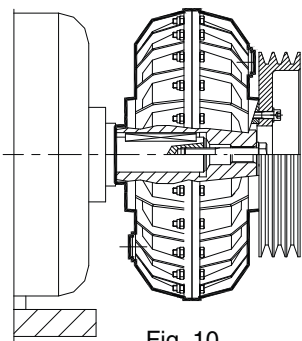

Fig. 10

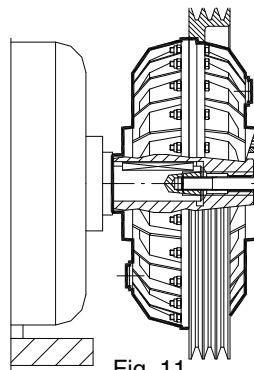

Fig. 11

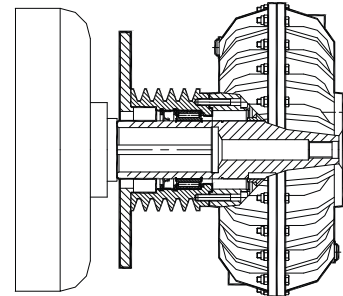

Fig. 12

BUILDING - CONSTRUCTION - MINING - BRICKS

- Tower Cranes
- Belt Conveyors
- Rotary kilns
- Crushers
- Rolling Mills
- Bucket elevators
- Rotating screens
- Rotary arrow
- Brick Moulders
- Kiln cars

TEXTILE

- Drum Tumblers
- Centrifuges
- Carding machines
- Industrial Washing machines
- Dryers

CHEMICAL - FOOD - CANNING

- Stirrers
- Dryers
- Decanters
- Rotating filters
- Soap cutters
- Calanders and gum mixers
- Palletizers
- Labelling Machine
- Bottling Plants
- Centrifugal separators

MECHANICAL ENGINEERING

- Twisting machines for rope and wire
- Rod iron straighteners
- Presses
- Profiling machines
- Drawbenches
- Cutters

AUTOMOTIVE INDUSTRY

- Balancing machines
- Gates open/closing drive

PAPER PROCESSING

- Winders
- Pulpers
- Mixers

TIMBER PROCESSING

- Drum barkers
- Hardboard presses
- Shredders

MARBLE

- Gantry cranes
- Multi-blade frames

ECOLOGY

- Blenders
- Sludge purification plant

CERAMICS

- Continuous and intermittent ball mills
- Mixers
- Presses

OTHERS

- Winches
- Windlasses
- Centrifugal and alternative compressors
- Suction and centrifugal fans
- Centrifugal pumps
- Fire pumps
- Elevators
- Cable cars
- Amusements park rides
- Haulage wagons in steelworks and mines
- Stack-up coating plants
- Sprayers
- Refineries
- Ski lift
- Sand mixers
- Fan & Blowers
- Refiners



**TECHNICAL SHEET
FOR COUPLING SELECTIONS**

Sheet
10-180 EN
Date
01-2017

COMPANY

CONTACT PERSON

ADDRESS

TELEPHONE N° FAX E-MAIL

MOTOR DATA

Motor Size kWrpm

Shaft Dia. mm Lenght mm Threated Bore mm Key mm

Engine Type kWrpm

Flywheel Dimension (SAE)

Bell Housing Dimension (SAE)

MACHINE DATA

Application

Coupling Version in line
 with pulley

Shaft Dia. mm Lenght mm Threated mm Key mm

Pulley: Pitch Dia. mm Groove Section and n

Montaggio: horizontal standard mounting inner drive
 vertical reverse mounting oute rdrive

FURTHER DETAILS

Absorbed Power during operation kW

Start-up at full load: YES NO

Start-up Number per hour

Reversal Cycle per hour

Overload Cycle per hour.....

Moment of Inertia J (kgm²)

Load Speed (rpm).....

Required Acceleration Time: Full load
Empty

Room Temperature °C.....

Enviromental Conditions.....

Specify any required options

Please enclose application description and sketch

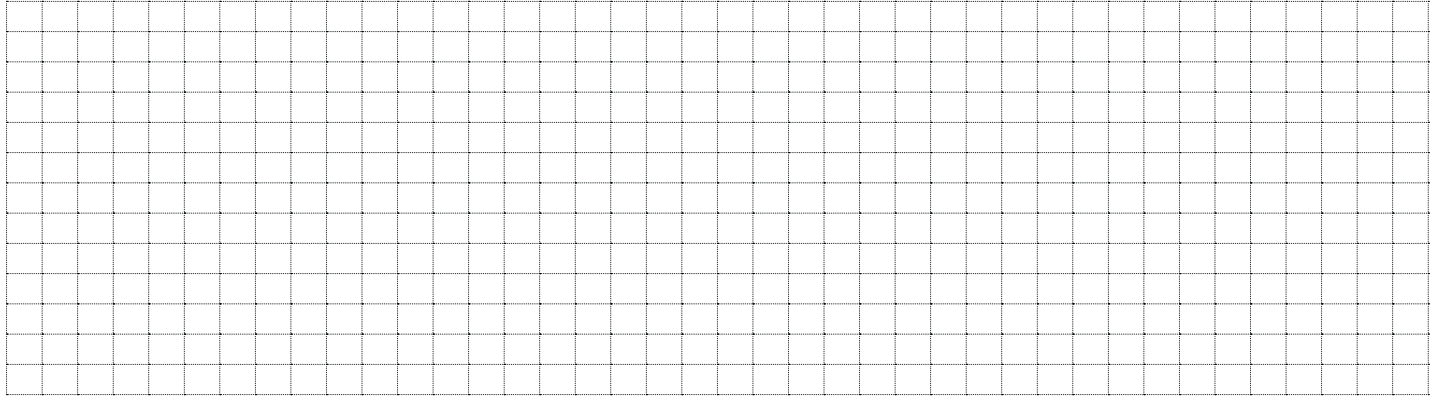



ROTOFLUID



ROTOFLEXI



ROTOFLUID CA



ROTOGEAR RE



ROTOMECH



ROTOGEAR AR



DRUM BRAKES BD



STEELFLEX



DRUM BRAKES CD



ROTOPIN

Discover more



Products

ON REQUEST,
ATEX CERTIFIED PRODUCTS
CAN BE SUPPLIED.



WESTCAR WORLDWIDE



Australia

France

Portugal

Belgium

Great Britain

Romania

Brazil

Holland

Russia

Canada

Iran

Singapore

Chile

Korea

South Africa

China

Morocco

Spain

Colombia

New Zealand

Sweden

Denmark

Norway

Thailand

Egypt

Pakistan

Turkey

Finland

Peru

USA

Distributor



WESTCAR s.r.l.

Headquarter

Via Monte Rosa, 14 - 20149 Milano (ITALY)

Ph. +39 02 761 10 319 - Fax +39 02 761 10 041

Production Plant

Via Venezia, 31 - 21058 Solbiate Olona (VA - ITALY)

info@westcar.it - www.westcar.it