

---

# Turcon<sup>®</sup> Stepseal<sup>®</sup> 2K



---

Single Acting

---

Rubber Energized Plastic Faced Seal

---

**Material:**  
Turcon<sup>®</sup> and Zurcon<sup>®</sup>

---





## ■ Turcon® Stepseal® 2K\*



### Description

Rod seals must exhibit no dynamic leakage to the atmosphere side under all operating conditions and must be statically completely leak tight when the machine is at a standstill.

Furthermore, they should achieve a high degree of mechanical efficiency through low friction and be easy to install in small grooves. Costs and service life must meet the high expectations of the operator.

The rod seal Turcon® Stepseal® 2K comes closest to satisfying these ideal demands. Since the first Stepseal® was patented and introduced to the market in 1972, Trelleborg Sealing Solutions has maintained the series as technically outstanding seal elements through continuous innovative further development of the design and of the Turcon® and Zurcon® materials. Turcon® Stepseal® 2K continues the tradition for improvement.

With the introduction of Stepseal® it was possible for the first time to arrange several seals, one behind the other, thus allowing statically and dynamically tight double-acting tandem seal configurations to be created, without

any disturbing build-up of intermediate pressure. The single-acting seal element is made of high-grade Turcon® or Zurcon® materials with outstanding sliding and wear resistance properties. It is installed according to ISO 7425/2 and Trelleborg Sealing Solutions standard grooves, using an O-Ring as energizing element.

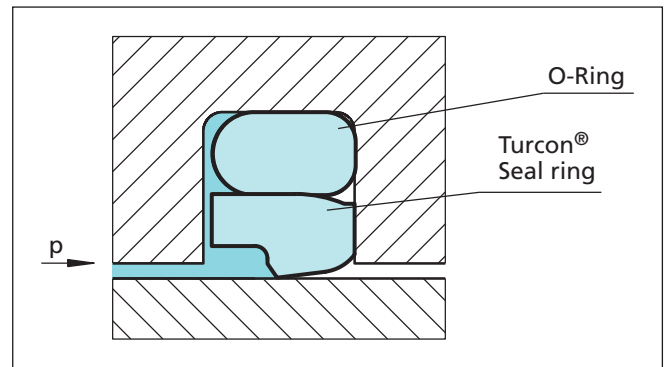

Figure 16 Turcon® Stepseal® 2K

**Turcon® and Zurcon®**  
*Low friction, no stick-slip  
 High form stability and wear resistance  
 Meets demanding service conditions  
 High flexibility for easy installation*

**Elastomer O-Ring**  
*High flexibility to compensate hardware tolerances and movement. Elastomer materials available to meet a wide variety of service conditions*

**O-Ring Relief Chamfer**  
*Reduced seal load under pressure.  
 Reduced seal friction*

**Geometry**  
*Patented and patent pending geometry  
 Proven seal edge design  
 Resist damage during installation and service*

**Contoured Rear**  
*Improved back-pumping of residual oil film for increased sealing efficiency.  
 Increased hardware tolerances  
 Increased radial clearance*

\* Patented and patent pending geometry



## Method of operation

The sealing performance of Stepseal® 2K (Figure 16) results from the hydrodynamic properties of the seal. The classic Stepseal® seal edge creates a steep contact pressure gradient on the high pressure side and a shallow contact pressure gradient on the low pressure side. The controlled pressure gradients minimize fluid adherence to the piston rod during the extending stroke, and enables residual fluid film on the rod to be returned into the system on the return stroke. This is united with new patented and patent applied design features which further improve the performance of Stepseal® 2K under severe service conditions.

The O-Ring relief chamfer reduces pressure loading on the seal, whereby contact with the rod is optimised and sealing performance is improved at high service pressures. The special high-lift rear chamfer combines a smooth downstream sealing face with the ability to meet large radial clearances and hardware tolerances.

Stepseal® 2K gives high static and dynamic sealing performance, and the build-up of intermediate pressure often found with tandem seal configurations (see Figure 17) is efficiently suppressed.

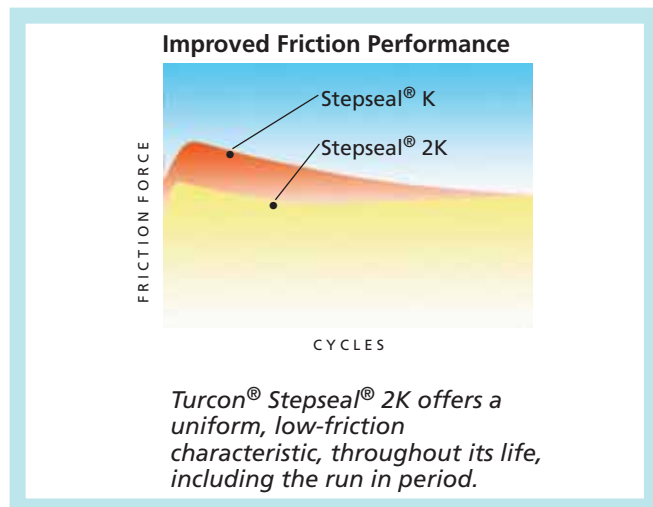
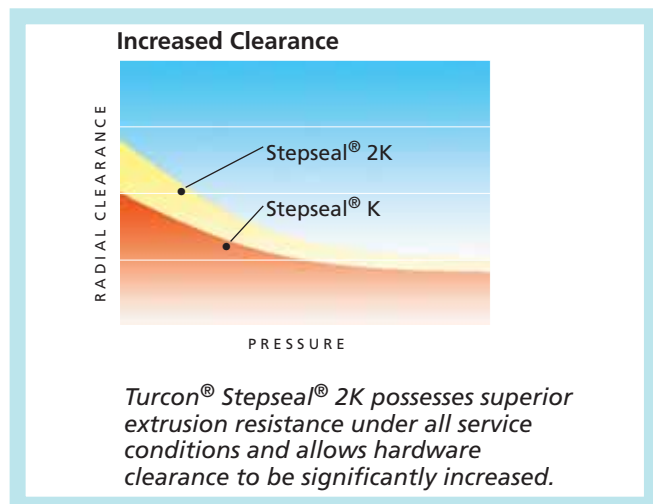

## Advantages

- High static and dynamic sealing effect
- High extrusion resistance, meets high hardware clearances
- Low friction, high efficiency
- Stick-slip free starting, no sticking
- High abrasion resistance, high operational reliability
- Wide range of application temperatures and high resistance to chemicals, depending on the choice of O-Ring material
- Simple installation without seal edge deformation
- Available for all diameters up to 2.600 mm rod dia.

## Technical data

Operating conditions:

Pressure: Up to 60 MPa

Speed: Up to 15 m/s with reciprocating movements, frequency up to 5 Hz

Temperature: -45 °C to +200 °C (depending on O-Ring material)

Media: Mineral oil-based hydraulic fluids, flame retardant hydraulic fluids, environmentally safe hydraulic fluids (bio-oils), phosphate ester, water and others, depending on the O-Ring material compatibility (see Table XI)

Clearance: The maximum permissible radial clearance  $S_{max}$  is shown in Table XII, as a function of the operating pressure and functional diameter.

### Important Note:

The above data are maximum values and cannot be used at the same time. e.g. the maximum operating speed depends on material type, pressure, temperature and gap value. Temperature range also dependent on medium.



## Materials

The following material combinations have proven effective for hydraulic applications:

All round material for hydraulic applications with reciprocating, short stroke or helical movements in mineral oils, flame retardant hydraulic fluids HFC, phosphate ester, bio-oils or fluids having less satisfactory lubricating properties:

Turcon® Stepseal® 2K: Turcon® M12  
 O-Ring: NBR, 70 Shore A N  
 FKM, 70 Shore A V  
 Set code: M12N or M12V

For medium to heavy applications with reciprocating movements in mineral oils and other media with good lubrication:

Turcon® Stepseal® 2K: Turcon® T46  
 O-Ring: NBR, 70 Shore A N  
 FKM, 70 Shore A V  
 Set code: T46N or T46V

For specific applications, all Turcon® materials are available. Other viable material combinations are listed in Table XI.

## Series

Different cross-section sizes are recommended as a function of the seal diameters.

Table XII, shows the relationship between the series number according to the seal diameter range and the different application class sizes. These application classes are:

Standard application: General applications in which no exceptional operating conditions exist.  
 Light application: Applications with demands for reduced friction or for smaller grooves.  
 Heavy-duty application: For exceptional operating loads such as high pressures, pressure peaks, etc.

**Table X Available range**

Series No.	Rod Diameter $d_N$ f8/h9
RSK00	2.0 - 130.0
RSK10	6.0 - 250.0
RSK20	10.0 - 450.0
RSK30	12.0 - 650.0
RSK40	38.0 - 650.0
RSK80	200.0 - 999.9
RSK50	256.0 - 999.9
RSK5X	1000.0 - 1200.0
RSK60	650.0 - 999.9
RSK6X	1000.0 - 2600.0

For the recommended range see Table XII.

## Application Examples

- Mobile hydraulic
- Construction Equipment
- Mining
- Standard cylinders
- Machine tools
- Injection moulding machines
- Presses
- Clamp cylinders
- Wind Turbines
- Automobile industry
- Shock absorbers
- Hydraulic hammers
- Servo hydraulics



## Redundant Sealing System

In many applications, secondary seal systems are demanded. Figure 17 shows such a tandem configuration with the Stepseal® 2K.

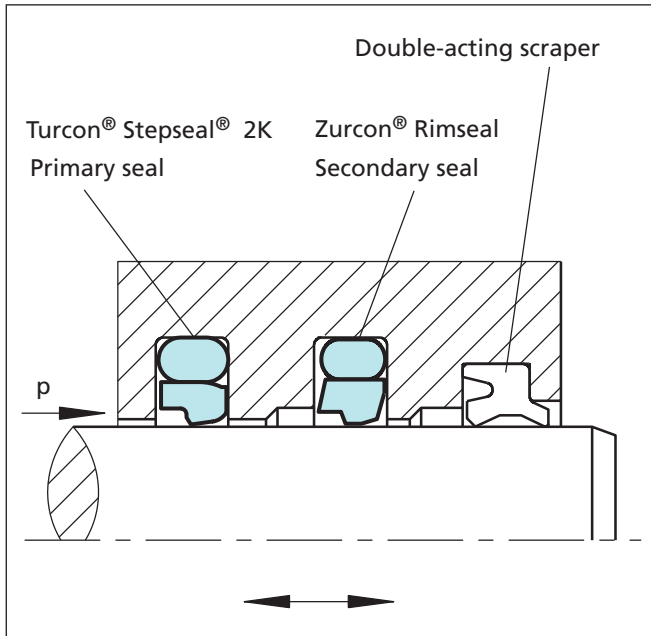

Figure 17 Turcon® Stepseal® 2K and Zurcon® Rimseal in tandem configuration

In this configuration it must be noted that a sufficiently large space is formed between the seals to take the hydraulic fluid, as shown in the figure.

Depending on the application and the operating conditions, the combination of different materials offers a further improvement in the sealing efficiency and the service life of the system, e.g. in hydraulic cylinders subject to high loads and under rough operating conditions, the primary seal should be made of Turcon® and the secondary seal of Zurcon®.



Stepseal® 2K elements should always be used in combination with a double-acting scraper to provide an optimum sealing effect.

The scraper Turcon® Excluder® 2, Turcon® Excluder® 5, Turcon® Excluder® F, Zurcon® Excluder® 500, DA17, DA22 and DA24 are well suited to such applications. For further details, please refer to our "Scrapers" catalogue.

**Table XI Turcon® and Zurcon® Materials for Stepseal® 2K**

Material, Applications, Properties	Code	O-Ring Material Shore A	Code	O-Ring Operating Temp.*°C	Mating Surface Material	MPa max. Dynamic
<b>Turcon® M12</b> First material choice for seals in linear motion Overall improved properties For new constructions and updating For all commonly applied hydraulic fluids including fluids with low lubrication performance Lowest friction and best sliding properties Lowest wear on seals Improved absorption of abrasive contaminants No wear or abrasion of counter surface Mineral fibre and Additives filled Colour: Dark grey	M12	NBR- 70	N	-30 to +100	Steel Steel hardened Steel chrome plated (rod) Steel plated (rod) Cast iron Stainless steel Titanium	50
		NBR- Low temp.	T	-45 to +80		
		FKM- 70	V	-10 to +200		
<b>Turcon® T05</b> For lubricating fluids Also for gas service Very low friction Very good sliding and sealing properties Colour: Turquoise	T05	NBR- 70	N	-30 to +100	Steel Steel hardened Steel chrome plated (rod)	20
		NBR- 70 Low temp.	T	-45 to +80		
		FKM- 70	V	-10 to +200		
<b>Turcon® T08</b> For lubricating fluids and linear motion Very high compressive strength and extrusion resistance Hard counter surfaces is recommended Bronze filled Colour: Light to dark brown, which may have variations in shading	T08	NBR- 70	N	-30 to +100	Steel hardened Steel chrome plated (rod) Cast iron	60
		NBR- 70 Low temp.	T	-45 to +80		
		FKM- 70	V	-10 to +200		
<b>Turcon® T10</b> For hydraulic and pneumatic For lubricating and non-lubricating fluids High extrusion resistance Good chemical resistance Not for electrically conducting fluids BAM tested Carbon, graphite filled Colour: Black	T10	NBR- 70	N	-30 to +100	Steel Steel hardened Steel chrome plated (rod) Stainless steel	40
		NBR- 70 Low temp.	T	-45 to +80		
		FKM- 70	V	-10 to +200		
		EPDM- 70	E**	-45 to +145		
<b>Turcon® T29</b> For lubricating and non-lubricating fluids Good extrusion resistance Surface texture is not suitable for gas sealing Not for electrically conducting fluids Carbon fibre filled Colour: Grey	T29	NBR- 70	N	-30 to +100	Steel Steel hardened Steel chrome plated (rod) Cast iron Stainless steel	30
		NBR- 70 Low temp.	T	-45 to +80		
		FKM- 70	V	-10 to +200		
		EPDM- 70	E**	-45 to +145		
<b>Turcon® T40</b> For lubricating and non-lubricating fluids High frequency and short strokes <b>Water hydraulics</b> Surface texture is not suitable for gas sealing Carbon fibre filled Colour: Grey.	T40	NBR- 70	N	-30 to +100	Steel Steel hardened Steel chrome plated (rod) Cast iron Stainless steel Aluminium	25
		NBR- 70 Low temp.	T	-45 to +80		
		FKM- 70	V	-10 to +200		
		EPDM- 70	E**	-45 to +145		

\* The O-Ring Operation Temperature is only valid in mineral hydraulic oil (except EPDM). \*\* Material not suitable for mineral oils. \*\*\* Max. ø 2200 BAM: Tested by "Bundesanstalt Materialprüfung, Germany".  Highlighted materials are standard.



# Turcon® Stepseal® 2K

Material, Applications, Properties	Code	O-Ring Material Shore A	Code	O-Ring Operating Temp.*°C	Mating Surface Material	MPa max. Dynamic
<b>Turcon® T46</b> For lubricated hydraulics in linear motion High compressive strength High extrusion resistance Very good sliding and wear properties BAM tested Bronze filled Colour: Light to dark brown, which may have variations in shading.	T46	NBR- 70	N	-30 to +100	Steel hardened Steel chrome plated (rod) Cast iron	50
		NBR- 70 Low temp.	T	-45 to +80		
		FKM- 70	V	-10 to +200		
<b>Zurcon® Z51***</b> For mineral oil based fluids <b>Very high abrasion and extrusion resistance</b> For counter surface with rougher surface finish Limited chemical resistance Max. working temperature 110 °C Cast polyurethane Colour: Yellow to light-brown.	Z51	NBR- 70	N	-30 to +100	Steel hardened Steel chrome plated (rod) Cast iron Stainless steel Ceramic coating	60
		NBR- 70 Low temp.	T	-45 to +80		
<b>Zurcon® Z80</b> For lubricating and non-lubricating fluids Water based fluids, air and gases Dry air pneumatics High abrasion and extrusion resistance For service in abrasive conditions and media with particles Good chemical resistance Limited temperature capability (-60 to +80 °C) UHMWPE (Ultra High Molecular Weight Polyethylene) Colour: White to off-white.	Z80	NBR- 70	N	-30 to +(100)	Steel hardened Steel chrome plated (rod) Stainless steel Aluminium Ceramic coating	35
		NBR- 70 Low temp.	T	-45 to +80		
		EPDM- 70	E**	-45 to(+145)		

\* The O-Ring Operation Temperature is only valid in mineral hydraulic oil (except EPDM). \*\* Material not suitable for mineral oils. \*\*\* Max. ø 2200 BAM: Tested by "Bundesanstalt Materialprüfung, Germany".  Highlighted materials are standard.





■ Installation Recommendation

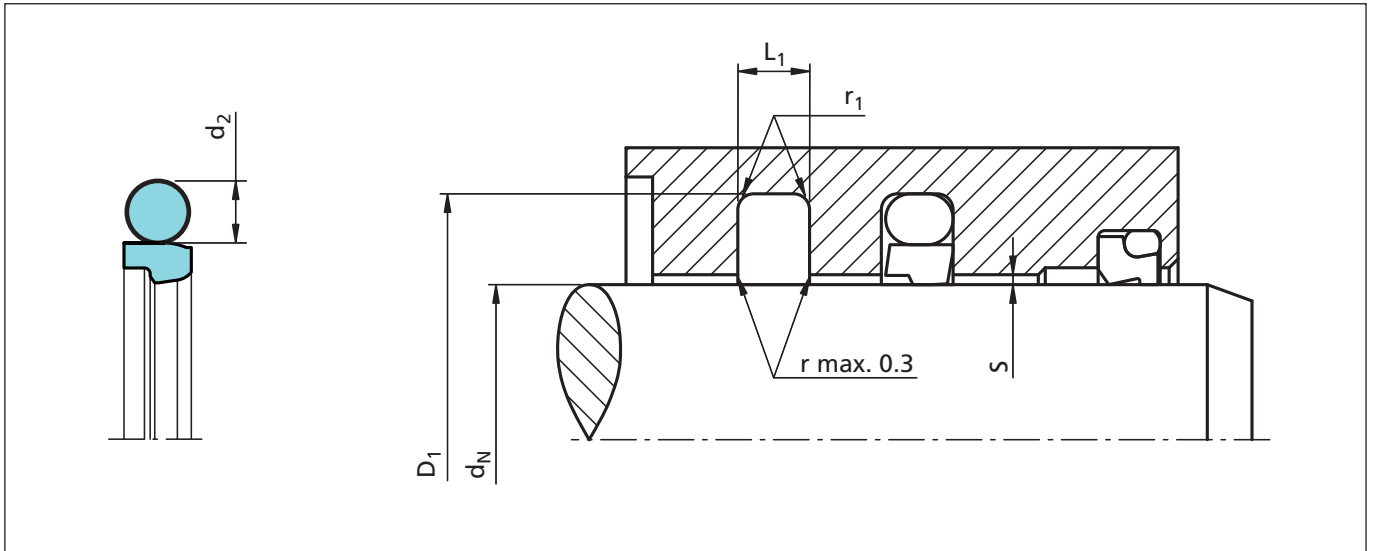

Figure 18 Installation drawing

Table XII Installation dimensions - Standard recommendations

Series No.	Rod Diameter			Groove Diameter	Groove Width	Radius	Radial Clearance			O-Ring Cross-Section
	$d_N$ f8/h9						S max. *			
	Standard Application	Light <sup>1)</sup> Application	Heavy Duty Application	$D_1$ H9	$L_1 + 0.2$	$r_1$	10 MPa	20 MPa	40 MPa	$d_2$
RSK0	3 - 7.9	8 - 18.9	-	$d_N + 4.9$	2.2	0.4	0.30	0.20	0.15	1.78
RSK1	8 - 18.9	19 - 37.9	-	$d_N + 7.3$	3.2	0.6	0.40	0.25	0.15	2.62
RSK2	19 - 37.9	38 - 199.9	8 - 18.9	$d_N + 10.7$	4.2	1.0	0.50	0.30	0.20	3.53
RSK3	38 - 199.9	200 - 255.9	19 - 37.9	$d_N + 15.1$	6.3	1.3	0.70	0.40	0.25	5.33
RSK4	200 - 255.9	256 - 649.9	38 - 199.9	$d_N + 20.5$	8.1	1.8	0.80	0.60	0.35	7.00
RSK8	256 - 649.9	650 - 999.9	200 - 255.9	$d_N + 24.0$	8.1	1.8	0.90	0.70	0.40	7.00
RSK5	650 - 999.9	1000 - 1200	256 - 649.9	$d_N + 27.3$	9.5	2.5	1.00	0.80	0.50	8.40
RSK6	$\geq 1000$ **	-	650 - 999.9	$d_N + 38.0$	13.8	3.0	1.20	0.90	0.60	12.00

\* At pressures > 40 MPa: Use diameter tolerance H8/f8 (bore/rod) in the area behind the seal; or consult TSS for alternative material or profiles. TSS Slydring®/Wear Rings are not applicable at very small radial clearance; please consult the Slydring® catalog.

\*\* All O-Rings with 12 mm cross section are delivered as a special profile ring.

<sup>1)</sup> For easier installation in closed grooves with small rod diameters (< 40 mm).



# Turcon® Stepseal® 2K

## Ordering example

Turcon® Stepseal® 2K complete with O-Ring, standard application, Series RSK4 (from Table XII).

Rod diameter:  $d_N = 250.0$  mm  
 TSS Part No.: RSK402500 (from Table XIII)

Select the material from Table XI. The corresponding code numbers are appended to the TSS Part No. (from Table XIII). Together these form the TSS Article Number. The TSS Article Number for all intermediate sizes not shown in Table XIII can be determined following the example below.  
 \*\* For diameters  $\geq 1000.0$  mm multiply only by factor 1.

Example: RSK6 for diameter 1200.0 mm. TSS Article No.: RSK6**X1200** -M12N.

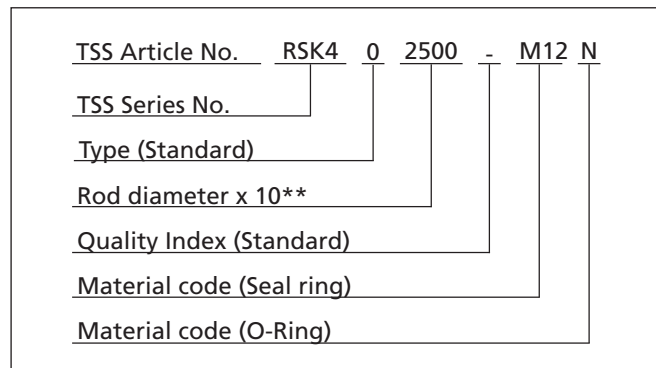

**Table XIII Installation dimensions / TSS Part No.**

Rod	Groove Diameter	Groove Width	TSS Part No.	O-Ring Size
$d_N$ f8/h9	$D_1$ H9	$L_1$ +0.2		
3.0	7.9	2.2	RSK000030	4.47 x 1.78
<b>4.0</b>	<b>8.9</b>	2.2	<b>RSK000040</b>	<b>5.6 x 1.8</b>
<b>5.0</b>	<b>9.9</b>	2.2	<b>RSK000050</b>	<b>6.7 x 1.8</b>
<b>6.0</b>	<b>10.9</b>	<b>2.2</b>	<b>RSK000060</b>	<b>7.65 x 1.78</b>
7.0	11.9	2.2	RSK000070	8.75 x 1.8
<b>8.0</b>	<b>12.9</b>	<b>2.2</b>	<b>RSK000080</b>	<b>9.5 x 1.8</b>
<b>8.0</b>	<b>15.3</b>	<b>3.2</b>	<b>RSK100080</b>	<b>10.77 x 2.62</b>
9.0	13.9	2.2	RSK000090	10.82 x 1.78
9.0	16.3	3.2	RSK100090	10.77 x 2.62
<b>10.0</b>	<b>14.9</b>	<b>2.2</b>	<b>RSK000100</b>	<b>11.8 x 1.8</b>
<b>10.0</b>	<b>17.3</b>	<b>3.2</b>	<b>RSK100100</b>	<b>12.37 x 2.62</b>
<b>12.0</b>	<b>16.9</b>	<b>2.2</b>	<b>RSK000120</b>	<b>14.00 x 1.78</b>
<b>12.0</b>	<b>19.3</b>	<b>3.2</b>	<b>RSK100120</b>	<b>13.94 x 2.62</b>
12.7	17.6	2.2	RSK000127	14.00 x 1.78
12.7	20.0	3.2	RSK100127	15.54 x 2.62
<b>14.0</b>	<b>18.9</b>	<b>2.2</b>	<b>RSK000140</b>	<b>15.60 x 1.78</b>
<b>14.0</b>	<b>21.3</b>	<b>3.2</b>	<b>RSK100140</b>	<b>17.12 x 2.62</b>
15.0	19.9	2.2	RSK000150	17.17 x 1.78
15.0	22.3	3.2	RSK100150	17.12 x 2.62
16.0	20.9	2.2	RSK000160	17.17 x 1.78
<b>16.0</b>	<b>23.3</b>	<b>3.2</b>	<b>RSK100160</b>	<b>18.72 x 2.62</b>
17.0	21.9	2.2	RSK000170	18.77 x 1.78
18.0	22.9	2.2	RSK000180	18.77 x 1.78
<b>18.0</b>	<b>25.3</b>	<b>3.2</b>	<b>RSK100180</b>	<b>20.29 x 2.62</b>

The rod diameters in **bold** type are in accordance with the recommendations of ISO 3320.

Other dimensions and all intermediate sizes up to 2600 mm diameter including imperial (inch) sizes can be supplied.

All O-Rings with 12 mm cross section are delivered as special profiling.



Rod	Groove Diameter	Groove Width	TSS Part No.	O-Ring Size
$d_N$ f8/h9	$D_1$ H9	$L_1$ +0.2		
19.0	29.7	4.2	RSK200190	23.40 x 3.53
<b>20.0</b>	<b>27.3</b>	<b>3.2</b>	<b>RSK100200</b>	<b>21.89 x 2.62</b>
<b>20.0</b>	<b>30.7</b>	<b>4.2</b>	<b>RSK200200</b>	<b>23.40 x 3.53</b>
<b>22.0</b>	<b>29.3</b>	<b>3.2</b>	<b>RSK100220</b>	<b>25.07 x 2.62</b>
<b>22.0</b>	<b>32.7</b>	<b>4.2</b>	<b>RSK200220</b>	<b>26.58 x 3.53</b>
24.0	31.3	3.2	RSK100240	26.64 x 2.62
<b>25.0</b>	<b>32.3</b>	<b>3.2</b>	<b>RSK100250</b>	<b>28.24 x 2.62</b>
<b>25.0</b>	<b>35.7</b>	<b>4.2</b>	<b>RSK200250</b>	<b>29.75 x 3.53</b>
25.4	32.7	3.2	RSK100254	28.24 x 2.62
25.4	36.1	4.2	RSK200254	29.75 x 3.53
26.0	33.3	3.2	RSK100260	28.24 x 2.62
26.0	36.7	4.2	RSK200260	29.75 x 3.53
28.0	35.3	3.2	RSK100280	29.82 x 2.62
<b>28.0</b>	<b>38.7</b>	<b>4.2</b>	<b>RSK200280</b>	<b>32.92 x 3.53</b>
28.575	35.875	3.2	RSK100286	31.42 x 2.62
30.0	37.3	3.2	RSK100300	32.99 x 2.62
30.0	40.7	4.2	RSK200300	34.52 x 3.53
32.0	39.3	3.2	RSK100320	34.59 x 2.62
<b>32.0</b>	<b>42.7</b>	<b>4.2</b>	<b>RSK200320</b>	<b>36.09 x 3.53</b>
35.0	42.3	3.2	RSK100350	37.77 x 2.62
35.0	45.7	4.2	RSK200350	37.69 x 3.53
36.0	43.3	3.2	RSK100360	39.34 x 2.62
<b>36.0</b>	<b>46.7</b>	<b>4.2</b>	<b>RSK200360</b>	<b>40.87 x 3.53</b>
37.0	44.3	3.2	RSK100370	39.34 x 2.62
37.0	47.7	4.2	RSK200370	40.87 x 3.53
38.0	48.7	4.2	RSK200380	40.87 x 3.53
38.0	53.1	6.3	RSK300380	43.82 x 5.33
<b>40.0</b>	<b>50.7</b>	<b>4.2</b>	<b>RSK200400</b>	<b>44.04 x 3.53</b>
<b>40.0</b>	<b>55.1</b>	<b>6.3</b>	<b>RSK300400</b>	<b>43.82 x 5.33</b>
42.0	52.7	4.2	RSK200420	47.22 x 3.53
42.0	57.1	6.3	RSK300420	46.99 x 5.33
43.0	53.7	4.2	RSK200430	47.22 x 3.53
44.45	59.55	6.3	RSK300444	50.17 x 5.33
<b>45.0</b>	<b>55.7</b>	<b>4.2</b>	<b>RSK200450</b>	<b>50.39 x 3.53</b>
<b>45.0</b>	<b>60.1</b>	<b>6.3</b>	<b>RSK300450</b>	<b>50.17 x 5.33</b>
48.0	58.7	4.2	RSK200480	51.5 x 3.55

The rod diameters in **bold** type are in accordance with the recommendations of ISO 3320.

Other dimensions and all intermediate sizes up to 2600 mm diameter including imperial (inch) sizes can be supplied.

All O-Rings with 12 mm cross section are delivered as special profiling.



## Turcon® Stepseal® 2K

Rod	Groove Diameter	Groove Width	TSS Part No.	O-Ring Size
$d_N$ f8/h9	$D_1$ H9	$L_1$ +0.2		
48.0	63.1	6.3	RSK300480	53.34 x 5.33
<b>50.0</b>	<b>60.7</b>	<b>4.2</b>	<b>RSK200500</b>	<b>53.57 x 3.53</b>
<b>50.0</b>	<b>65.1</b>	<b>6.3</b>	<b>RSK300500</b>	<b>56.52 x 5.33</b>
50.8	61.5	4.2	RSK200508	53.57 x 3.53
50.8	65.9	6.3	RSK300508	56.52 x 5.33
52.0	62.7	4.2	RSK200520	56.74 x 3.53
52.0	67.1	6.3	RSK300520	56.52 x 5.33
54.0	69.1	6.3	RSK300540	59.69 x 5.33
55.0	65.7	4.2	RSK200550	59.92 x 3.53
55.0	70.1	6.3	RSK300550	59.69 x 5.33
<b>56.0</b>	<b>66.7</b>	<b>4.2</b>	<b>RSK200560</b>	<b>59.92 x 3.53</b>
<b>56.0</b>	<b>71.1</b>	<b>6.3</b>	<b>RSK300560</b>	<b>62.87 x 5.33</b>
56.0	76.5	8.1	RSK400560	63 x 7.0
57.0	72.1	6.3	RSK300570	62.87 x 5.33
59.0	69.7	4.2	RSK200590	63.09 x 3.53
60.0	70.7	4.2	RSK200600	63.09 x 3.53
60.0	75.1	6.3	RSK300600	66.04 x 5.33
<b>63.0</b>	<b>73.7</b>	<b>4.2</b>	<b>RSK200630</b>	<b>66.27 x 3.53</b>
<b>63.0</b>	<b>78.1</b>	<b>6.3</b>	<b>RSK300630</b>	<b>69.22 x 5.33</b>
63.5	78.6	6.3	RSK300635	69.22 x 5.33
65.0	75.7	4.2	RSK200650	69.44 x 3.53
65.0	80.1	6.3	RSK300650	69.22 x 5.33
67.0	77.7	4.2	RSK200670	72.62 x 3.53
69.0	84.1	6.3	RSK300690	75.57 x 5.33
70.0	80.7	4.2	RSK200700	75.79 x 3.53
<b>70.0</b>	<b>85.1</b>	<b>6.3</b>	<b>RSK300700</b>	<b>75.57 x 5.33</b>
70.0	90.5	8.1	RSK400700	78 x 7.0
72.0	82.7	4.2	RSK200720	75.79 x 3.53
73.0	88.1	6.3	RSK300730	78.74 x 5.33
75.0	85.7	4.2	RSK200750	78.97 x 3.53
75.0	90.1	6.3	RSK300750	81.92 x 5.33
76.2	91.3	6.3	RSK300762	81.92 x 5.33
78.0	93.1	6.3	RSK300780	85.09 x 5.33
80.0	90.7	4.2	RSK200800	85.32 x 3.53
<b>80.0</b>	<b>95.1</b>	<b>6.3</b>	<b>RSK300800</b>	<b>85.09 x 5.33</b>
80.0	100.5	8.1	RSK400800	88 x 7.0

The rod diameters in **bold** type are in accordance with the recommendations of ISO 3320.  
Other dimensions and all intermediate sizes up to 2600 mm diameter including imperial (inch) sizes can be supplied.  
All O-Rings with 12 mm cross section are delivered as special profiling.



Rod	Groove Diameter	Groove Width	TSS Part No.	O-Ring Size
$d_N$ f8/h9	$D_1$ H9	$L_1$ +0.2		
82.5	97.6	6.3	RSK300825	88.27 x 5.33
83.0	93.7	4.2	RSK200830	88.49 x 3.53
85.0	95.7	4.2	RSK200850	88.49 x 3.53
85.0	100.1	6.3	RSK300850	91.44 x 5.33
85.0	105.5	8.1	RSK400850	93 x 7.0
89.0	104.1	6.3	RSK300890	94.62 x 5.33
90.0	100.7	4.2	RSK200900	94.84 x 3.53
<b>90.0</b>	<b>105.1</b>	<b>6.3</b>	<b>RSK300900</b>	<b>94.62 x 5.33</b>
90.0	110.5	8.1	RSK400900	98 x 7.0
92.0	102.7	4.2	RSK200920	98.02 x 3.53
92.0	107.1	6.3	RSK300920	97.79 x 5.33
95.0	105.7	4.2	RSK200950	101.19 x 3.53
95.0	110.1	6.3	RSK300950	100.97 x 5.33
100.0	110.7	4.2	RSK201000	104.37 x 3.53
<b>100.0</b>	<b>115.1</b>	<b>6.3</b>	<b>RSK301000</b>	<b>107.32 x 5.33</b>
100.0	120.5	8.1	RSK401000	108 x 7.0
101.6	116.7	6.3	RSK301016	107.32 x 5.33
104.7	119.8	6.3	RSK301047	110.49 x 5.33
105.0	120.1	6.3	RSK301050	110.49 x 5.33
105.0	125.5	8.1	RSK401050	113.67 x 7.0
110.0	120.7	4.2	RSK201100	113.89 x 3.53
<b>110.0</b>	<b>125.1</b>	<b>6.3</b>	<b>RSK301100</b>	<b>116.84 x 5.33</b>
110.0	130.5	8.1	RSK401100	116.84 x 7.0
115.0	130.1	6.3	RSK301150	120.02 x 5.33
120.0	135.1	6.3	RSK301200	126.37 x 5.33
120.0	145.5	8.1	RSK401200	129.54 x 7.0
<b>125.0</b>	<b>140.1</b>	<b>6.3</b>	<b>RSK301250</b>	<b>129.54 x 5.33</b>
125.0	145.5	8.1	RSK401250	132.72 x 7.0
125.4	140.5	6.3	RSK301254	132.72 x 5.33
127.0	142.1	6.3	RSK301270	132.72 x 5.33
130.0	145.1	6.3	RSK301300	135.89 x 5.33
130.0	150.5	8.1	RSK401300	139.07 x 7.0
132.0	147.1	6.3	RSK301320	139.07 x 5.33
135.0	145.7	4.2	RSK201350	139.29 x 3.53
135.0	150.1	6.3	RSK301350	142.24 x 5.33
137.0	152.1	6.3	RSK301370	142.24 x 5.33

The rod diameters in **bold** type are in accordance with the recommendations of ISO 3320.  
 Other dimensions and all intermediate sizes up to 2600 mm diameter including imperial (inch) sizes can be supplied.  
 All O-Rings with 12 mm cross section are delivered as special profiling.



## Turcon® Stepseal® 2K

Rod	Groove Diameter	Groove Width	TSS Part No.	O-Ring Size
$d_N$ f8/h9	$D_1$ H9	$L_1$ +0.2		
138.0	153.1	6.3	RSK301380	142.24 x 5.33
140.0	150.7	4.2	RSK201400	145.64 x 3.53
<b>140.0</b>	<b>155.1</b>	<b>6.3</b>	<b>RSK301400</b>	<b>145.42 x 5.33</b>
140.0	160.5	8.1	RSK401400	148.59 x 7.0
140.5	155.6	6.3	RSK301405	145.42 x 5.33
145.0	160.1	6.3	RSK301450	151.77 x 5.33
145.0	165.5	8.1	RSK401450	151.77 x 7.0
150.0	165.1	6.3	RSK301500	158.12 x 5.33
150.0	170.5	8.1	RSK401500	158.12 x 7.0
153.0	168.1	6.3	RSK301530	158.12 x 5.33
155.0	170.1	6.3	RSK301550	158.12 x 5.33
<b>160.0</b>	<b>175.1</b>	<b>6.3</b>	<b>RSK301600</b>	<b>164.47 x 5.33</b>
<b>160.0</b>	<b>180.5</b>	<b>8.1</b>	<b>RSK401600</b>	<b>170.82 x 7.0</b>
165.0	180.1	6.3	RSK301650	170.82 x 5.33
170.0	185.1	6.3	RSK301700	177.17 x 5.33
170.0	190.5	8.1	RSK401700	177.17 x 7.0
173.0	188.1	6.3	RSK301730	177.17 x 5.33
175.0	190.1	6.3	RSK301750	183.52 x 5.33
<b>180.0</b>	<b>195.1</b>	<b>6.3</b>	<b>RSK301800</b>	<b>183.52 x 5.33</b>
<b>180.0</b>	<b>200.5</b>	<b>8.1</b>	<b>RSK401800</b>	<b>189.87 x 7.0</b>
185.0	200.1	6.3	RSK301850	189.87 x 5.33
185.0	205.5	8.1	RSK401850	196.22 x 7.0
190.0	205.1	6.3	RSK301900	196.22 x 5.33
190.0	210.5	8.1	RSK401900	196.22 x 7.0
195.0	210.1	6.3	RSK301950	202.57 x 5.33
200.0	215.1	6.3	RSK302000	208.92 x 5.33
<b>200.0</b>	<b>220.5</b>	<b>8.1</b>	<b>RSK402000</b>	<b>208.92 x 7.0</b>
205.0	225.5	8.1	RSK402050	215.27 x 7.0
210.0	230.5	8.1	RSK402100	215.27 x 7.0
211.0	231.5	8.1	RSK402110	215.27 x 7.0
212.0	232.5	8.1	RSK402120	227.97 x 7.0
215.0	235.5	8.1	RSK402150	227.97 x 7.0
<b>220.0</b>	<b>240.5</b>	<b>8.1</b>	<b>RSK402200</b>	<b>227.97 x 7.0</b>
225.0	245.5	8.1	RSK402250	240.67 x 7.0
230.0	245.1	6.3	RSK302300	234.32 x 5.33
230.0	250.5	8.1	RSK402300	240.67 x 7.0

The rod diameters in **bold** type are in accordance with the recommendations of ISO 3320.

Other dimensions and all intermediate sizes up to 2600 mm diameter including imperial (inch) sizes can be supplied.

All O-Rings with 12 mm cross section are delivered as special profiling.



Rod	Groove Diameter	Groove Width	TSS Part No.	O-Ring Size
$d_N$ f8/h9	$D_1$ H9	$L_1$ +0.2		
235.0	255.5	8.1	RSK402350	240.67 x 7.0
240.0	260.5	8.1	RSK402400	253.37 x 7.0
245.0	265.5	8.1	RSK402450	253.37 x 7.0
<b>250.0</b>	<b>270.5</b>	<b>8.1</b>	<b>RSK402500</b>	<b>266.07 x 7.0</b>
260.0	284.0	8.1	RSK802600	266.07 x 7.0
265.0	289.0	8.1	RSK802650	278.77 x 7.0
270.0	290.5	8.1	RSK402700	278.77 x 7.0
270.0	294.0	8.1	RSK802700	278.77 x 7.0
275.0	299.0	8.1	RSK802750	291.47 x 7.0
<b>280.0</b>	<b>304.0</b>	<b>8.1</b>	<b>RSK802800</b>	<b>291.47 x 7.0</b>
285.0	309.0	8.1	RSK802850	291.47 x 7.0
290.0	314.0	8.1	RSK802900	304.17 x 7.0
295.0	319.0	8.1	RSK802950	304.17 x 7.0
300.0	320.5	8.1	RSK403000	304.17 x 7.0
300.0	324.0	8.1	RSK803000	316.87 x 7.0
310.0	334.0	8.1	RSK803100	316.87 x 7.0
<b>320.0</b>	<b>344.0</b>	<b>8.1</b>	<b>RSK803200</b>	<b>329.57 x 7.0</b>
330.0	354.0	8.1	RSK803300	342.27 x 7.0
340.0	364.0	8.1	RSK803400	354.97 x 7.0
350.0	370.5	8.1	RSK403500	354.97 x 7.0
350.0	374.0	8.1	RSK803500	367.67 x 7.0
<b>360.0</b>	<b>384.0</b>	<b>8.1</b>	<b>RSK803600</b>	<b>367.67 x 7.0</b>
365.0	389.0	8.1	RSK803650	380.37 x 7.0
370.0	394.0	8.1	RSK803700	380.37 x 7.0
375.0	399.0	8.1	RSK803750	393.07 x 7.0
380.0	404.0	8.1	RSK803800	393.07 x 7.0
390.0	414.0	8.1	RSK803900	405.26 x 7.0
400.0	424.0	8.1	RSK804000	417.96 x 7.0
410.0	434.0	8.1	RSK804100	417.96 x 7.0
420.0	444.0	8.1	RSK804200	430.66 x 7.0
430.0	454.0	8.1	RSK804300	443.36 x 7.0
435.0	459.0	8.1	RSK804350	443.36 x 7.0
440.0	464.0	8.1	RSK804400	456.06 x 7.0
450.0	474.0	8.1	RSK804500	468.76 x 7.0
460.0	484.0	8.1	RSK804600	468.76 x 7.0
470.0	494.0	8.1	RSK804700	481.46 x 7.0

The rod diameters in **bold** type are in accordance with the recommendations of ISO 3320.  
 Other dimensions and all intermediate sizes up to 2600 mm diameter including imperial (inch) sizes can be supplied.  
 All O-Rings with 12 mm cross section are delivered as special profiling.



# Turcon® Stepseal® 2K

Rod	Groove Diameter	Groove Width	TSS Part No.	O-Ring Size
<b>d<sub>N</sub></b> f8/h9	<b>D<sub>1</sub></b> H9	<b>L<sub>1</sub></b> +0.2		
480.0	504.0	8.1	RSK804800	494.16 x 7.0
485.0	509.0	8.1	RSK804850	494.16 x 7.0
490.0	514.0	8.1	RSK804900	506.86 x 7.0
500.0	524.0	8.1	RSK805000	506.86 x 7.0
510.0	534.0	8.1	RSK805100	532.26 x 7.0
520.0	544.0	8.1	RSK805200	532.26 x 7.0
525.0	549.0	8.1	RSK805250	532.26 x 7.0
530.0	554.0	8.1	RSK805300	557.66 x 7.0
540.0	564.0	8.1	RSK805400	557.66 x 7.0
550.0	574.0	8.1	RSK805500	557.66 x 7.0
560.0	584.0	8.1	RSK805600	582.68 x 7.0
570.0	594.0	8.1	RSK805700	582.68 x 7.0
580.0	604.0	8.1	RSK805800	608.08 x 7.0
585.0	609.0	8.1	RSK805850	608.08 x 7.0
590.0	614.0	8.1	RSK805900	608.08 x 7.0
600.0	624.0	8.1	RSK806000	608.08 x 7.0
610.0	634.0	8.1	RSK806100	633.48 x 7.0
620.0	644.0	8.1	RSK806200	633.48 x 7.0
630.0	654.0	8.1	RSK806300	658.88 x 7.0
640.0	664.0	8.1	RSK806400	658.88 x 7.0
650.0	677.3	9.5	RSK506500	663 x 8.4
656.0	683.3	9.5	RSK506560	669 x 8.4
660.0	687.3	9.5	RSK506600	673 x 8.4
680.0	707.3	9.5	RSK506800	693 x 8.4
685.0	712.3	9.5	RSK506850	698 x 8.4
700.0	724.0	8.1	RSK807000	712 x 7.0
700.0	727.3	9.5	RSK507000	713 x 8.4
710.0	737.3	9.5	RSK507100	723 x 8.4
730.0	757.3	9.5	RSK507300	743 x 8.4
760.0	787.3	9.5	RSK507600	773 x 8.4
765.0	792.3	9.5	RSK507650	778 x 8.4
780.0	807.3	9.5	RSK507800	793 x 8.4
790.0	817.3	9.5	RSK507900	803 x 8.4
800.0	827.3	9.5	RSK508000	813 x 8.4
810.0	837.3	9.5	RSK508100	823 x 8.4
820.0	847.3	9.5	RSK508200	833 x 8.4

The rod diameters in **bold** type are in accordance with the recommendations of ISO 3320.  
 Other dimensions and all intermediate sizes up to 2600 mm diameter including imperial (inch) sizes can be supplied.  
 All O-Rings with 12 mm cross section are delivered as special profiling.





Rod	Groove Diameter	Groove Width	TSS Part No.	O-Ring Size
<b>d<sub>N</sub></b> f8/h9	<b>D<sub>1</sub></b> H9	<b>L<sub>1</sub></b> +0.2		
830.0	857.3	9.5	RSK508300	843 x 8.4
850.0	877.3	9.5	RSK508500	863 x 8.4
870.0	897.3	9.5	RSK508700	883 x 8.4
880.0	907.3	9.5	RSK508800	893 x 8.4
885.0	912.3	9.5	RSK508850	898 x 8.4
890.0	917.3	9.5	RSK508900	903 x 8.4
930.0	957.3	9.5	RSK509300	943 x 8.4
955.0	982.3	9.5	RSK509550	968 x 8.4
1000.0	1038.0	13.8	RSK6X1000	1016 x 12
1035.0	1073.0	13.8	RSK6X1035	1051 x 12
1040.0	1067.3	9.5	RSK5X1040	1053 x 8.4
1040.0	1078.0	13.8	RSK6X1040	1056 x 12
1050.0	1077.3	9.5	RSK5X1050	1063 x 8.4
1050.0	1088.0	13.8	RSK6X1050	1066 x 12
1100.0	1138.0	13.8	RSK6X1100	1116 x 12
1120.0	1147.3	9.5	RSK5X1120	1133 x 8.4
1120.0	1158.0	13.8	RSK6X1120	1136 x 12
1200.0	1227.3	9.5	RSK5X1200	1213 x 8.4
1200.0	1238.0	13.8	RSK6X1200	1216 x 12
1330.0	1368.0	13.8	RSK6X1330	1346 x 12
1500.0	1538.0	13.8	RSK6X1500	1516 x 12
1600.0	1638.0	13.8	RSK6X1600	1616 x 12
2000.0	2038.0	13.8	RSK6X2000	2016 x 12
2600.0	2638.0	13.8	RSK6X2600	2616 x 12

The rod diameters in **bold** type are in accordance with the recommendations of ISO 3320.  
 Other dimensions and all intermediate sizes up to 2600 mm diameter including imperial (inch) sizes can be supplied.  
 All O-Rings with 12 mm cross section are delivered as special profiling.



■ Installation according to ISO 7425, Part 2

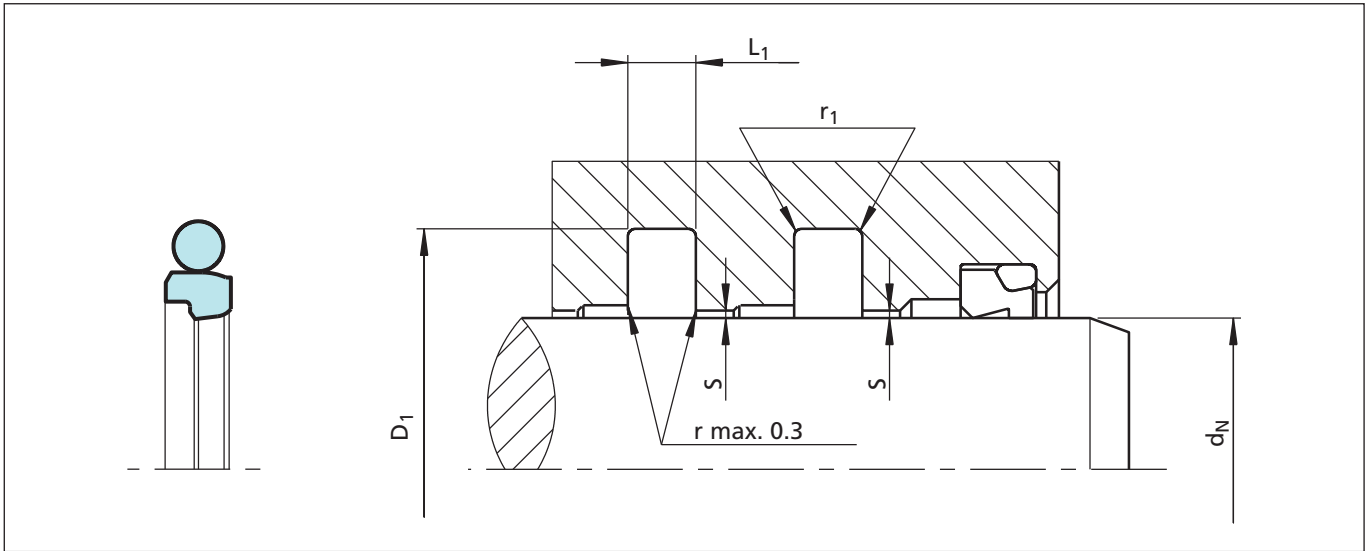

Figure 19 Installation drawing

Dimensions to ISO 7425/2.

Turcon® Stepseal® 2K seals to fit grooves to ISO 7425/2 are additionally marked with a chamfer on the corner of the outside diameter.

The dimensions for clearance S, depending on seal dimensions (groove width) and pressure, can be taken from Table XII.

For dimensions d<sub>N</sub>, D<sub>1</sub> and L<sub>1</sub> please refer to Table XV.

Technical data, recommendations and material selection as per the standard version.

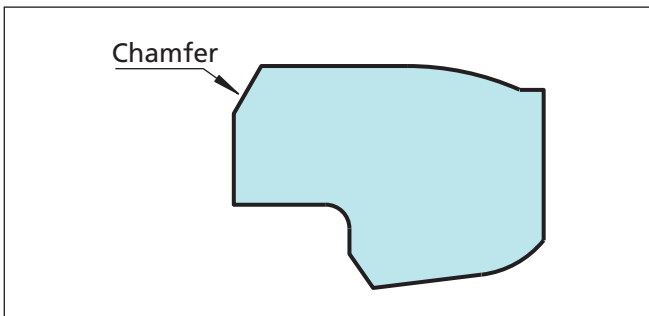

Figure 20 Marking of the ISO version

Table XIV ISO standard series

Series No.	Available for Rod Sizes	Rod Dia. ISO Std.	Radial Depth ISO Std.	Axial Width ISO Std.	Groove Dia. Tol. ISO Std.	Groove Radius ISO Std.
		f8		+0.25/-0		
RSKA	6 - 130	6 - 14	2.50	2.2	ø6 - ø100 (H9) ø110 - ø360 (H8)	ø6 - ø63 (r1=0.5) ø63 - ø360 (r1=0.9)
RSKB	10 - 245	12 - 25	3.75	3.2	ø6 - ø100 (H9) ø110 - ø360 (H8)	ø6 - ø63 (r1=0.5) ø63 - ø360 (r1=0.9)
RSKC	19 - 455	20 - 63	5.50	4.2	ø6 - ø100 (H9) ø110 - ø360 (H8)	ø6 - ø63 (r1=0.5) ø63 - ø360 (r1=0.9)
RSKD	38 - 655	56 - 180	7.75	6.3	ø6 - ø100 (H9) ø110 - ø360 (H8)	ø6 - ø63 (r1=0.5) ø63 - ø360 (r1=0.9)
RSKE	120 - 655	160 - 250	10.50	8.1	ø6 - ø100 (H9) ø110 - ø360 (H8)	ø6 - ø63 (r1=0.5) ø63 - ø360 (r1=0.9)
RSKF	200 - 655	280 - 360	12.25	8.1	ø6 - ø100 (H9) ø110 - ø360 (H8)	ø6 - ø63 (r1=0.5) ø63 - ø360 (r1=0.9)



## Ordering example

Turcon® Stepseal® 2K to ISO 7425/2

Rod diameter:  $d_N = 63.0$  mm  
 Groove width:  $L_1 = 4.2$  mm  
 TSS Part No. RSKC00630

Select the material from Table XI. The corresponding code numbers are appended to the TSS Part No. (from Table XV). Together these form the TSS Article Number.

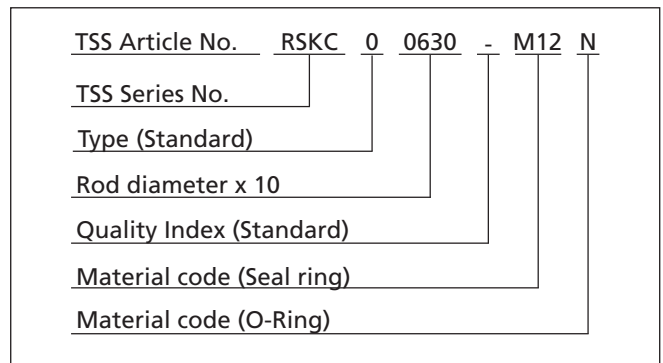

**Table XV Installation dimensions to ISO 7425/2 / TSS Part No.**

Rod	Groove Diameter	Groove Width	$r_1$	TSS Part No.	O-Ring Size
$d_N$ f8/h9	$D_1$ H9	$L_1$ +0.25			
6.0	11.0	2.2	0.5	RSKA00060	7.65 x 1.78
8.0	13.0	2.2	0.5	RSKA00080	9.5 x 1.8
10.0	15.0	2.2	0.5	RSKA00100	11.8 x 1.8
12.0	17.0	2.2	0.5	RSKA00120	14.0 x 1.78
12.0	19.5	3.2	0.5	RSKB00120	13.94 x 2.62
14.0	19.0	2.2	0.5	RSKA00140	15.60 x 1.78
14.0	21.5	3.2	0.5	RSKB00140	17.12 x 2.62
16.0	23.5	3.2	0.5	RSKB00160	18.72 x 2.62
18.0	25.5	3.2	0.5	RSKB00180	20.29 x 2.62
20.0	27.5	3.2	0.5	RSKB00200	23.47 x 2.62
20.0	31.0	4.2	0.5	RSKC00200	25.00 x 3.53
22.0	29.5	3.2	0.5	RSKB00220	25.07 x 2.62
22.0	33.0	4.2	0.5	RSKC00220	26.58 x 3.53
25.0	32.5	3.2	0.5	RSKB00250	28.24 x 2.62
25.0	36.0	4.2	0.5	RSKC00250	29.75 x 3.53
28.0	39.0	4.2	0.5	RSKC00280	32.92 x 3.53
32.0	43.0	4.2	0.5	RSKC00320	36.09 x 3.53
36.0	47.0	4.2	0.5	RSKC00360	40.87 x 3.53
40.0	51.0	4.2	0.5	RSKC00400	44.04 x 3.53
45.0	56.0	4.2	0.5	RSKC00450	50.39 x 3.53
50.0	61.0	4.2	0.5	RSKC00500	53.57 x 3.53
56.0	67.0	4.2	0.5	RSKC00560	59.92 x 3.53
56.0	71.5	6.3	0.9	RSKD00560	62.87 x 5.33
63.0	74.0	4.2	0.5	RSKC00630	66.27 x 3.53

Rod	Groove Diameter	Groove Width	$r_1$	TSS Part No.	O-Ring Size
$d_N$ f8/h9	$D_1$ H9	$L_1$ +0.25			
63.0	78.5	6.3	0.9	RSKD00630	69.22 x 5.33
70.0	85.5	6.3	0.9	RSKD00700	75.57 x 5.33
80.0	95.5	6.3	0.9	RSKD00800	85.09 x 5.33
90.0	105.5	6.3	0.9	RSKD00900	94.62 x 5.33
100.0	115.5	6.3	0.9	RSKD01000	107.32 x 5.33
110.0	125.5	6.3	0.9	RSKD01100	116.84 x 5.33
125.0	140.5	6.3	0.9	RSKD01250	132.72 x 5.33
140.0	155.5	6.3	0.9	RSKD01400	145.42 x 5.33
160.0	175.5	6.3	0.9	RSKD01600	164.47 x 5.33
160.0	181.0	8.1	0.9	RSKE01600	170.82 x 7.0
180.0	195.5	6.3	0.9	RSKD01800	189.87 x 5.33
180.0	201.0	8.1	0.9	RSKE01800	189.87 x 7.0
200.0	221.0	8.1	0.9	RSKE02000	208.92 x 7.0
220.0	241.0	8.1	0.9	RSKE02200	227.97 x 7.0
250.0	271.0	8.1	0.9	RSKE02500	266.07 x 7.0
280.0	304.5	8.1	0.9	RSKF02800	291.47 x 7.0
320.0	344.5	8.1	0.9	RSKF03200	329.57 x 7.0
360.0	384.5	8.1	0.9	RSKF03600	367.67 x 7.0

Above table only includes ISO rod diameters.

Other dimensions and all intermediate sizes up to 2600 mm diameter including imperial (inch) sizes can be supplied.



# Turcon® Stepseal® 2K

---