

FEG PLUS[®] Module: 5-HFM-887-PVI

Tubular Ultrafiltration One-Inch Modules for Industrial Applications

PRODUCT DESCRIPTION

KSS Part Number (KPN):	0711667
Membrane Chemistry:	PVDF
Membrane Type:	HFM (neutral)
Membrane Area:	1.1 ft ² (0.10 m ²)
Molecular Weight Cut-Off:	100,000 Dalton (nominal)
Housing Construction:	CPVC
Seal:	CPVC Insert (Epoxyed in Place)
Gasket:	Viton [®]
Interconnecting Components:	See second page

OPERATING AND DESIGN INFORMATION*

Maximum Inlet Pressure:	90 psi @ 140°F (6.2 bar @ 60°C)
Minimum Outlet Pressure:	5 psi (0.3 bar)
Maximum Operating Temperature (at pH 8.0):	140°F (60°C)
Maximum Permeate Side Back Pressure:	5 psi (0.3 bar)
Maximum Feed Side Pressure Drop:	5 psi @ 140°F (0.3 bar @ 60°C)
Allowable pH - Continuous Exposure:	2.0 - 10.0 @ 140°F (60°C)
Allowable pH - Short Term Exposure:	1.5 - 10.5 @ 140°F (60°C)

*Consult KSS Process Technology Group for specific applications.

FEED FLOW VS. PRESSURE DROP**

Circulation Flow		Crossflow Velocity		Pressure Drop	
gpm	m ³ /hr	fps	m/s	psi	bar
19	4.3	7.8	2.4	1.0	0.07
30	6.8	12.3	3.7	2.2	0.15
38	8.6	15.5	4.7	3.0	0.21

**Data based on Water at 77° F (25°C) and specific gravity of 1.0. Circulation rates exhibit variances of 15%.

NOMINAL DIMENSIONS

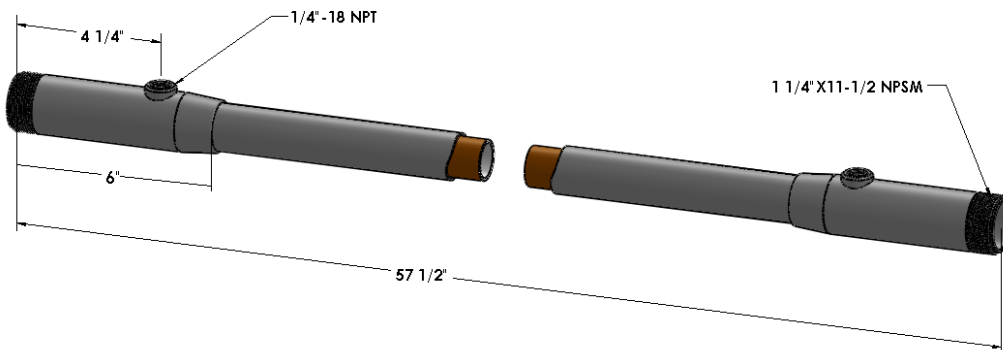

OPERATING GUIDELINES

Ancillary Parts

KSS recommends that these membranes be used with KSS supplied ancillary parts. Sealing is provided by gaskets. No additional sealing compound or tape is recommended for use on threaded connections.

Membrane Incompatibility

Prior to exposing the membrane to any chemical, the chemical should be reviewed by Koch Separation Solutions. Aside from the listed chemicals below, synthetic coolants, semi-synthetic coolants, kerosenes, naphtha, gasoline, floc polymers may affect membrane performance.

Chemicals that should be avoided include the following:

- **Aprotic Solvent** (e.g., Dimethyl Formamide, Dimethyl Acetamide, N-Methyl Pyrolidine, etc.)
- **Chlorinated Solvents** (e.g., Methylene Chloride, Chloroform, Carbon Tetrachloride, etc.)
- **Ketones** (e.g., Acetone, Diacetone Alcohol, etc.)
- **Silicones** or Silicone based Defoamers (e.g., Siloxane)

FEG PLUS MODULE

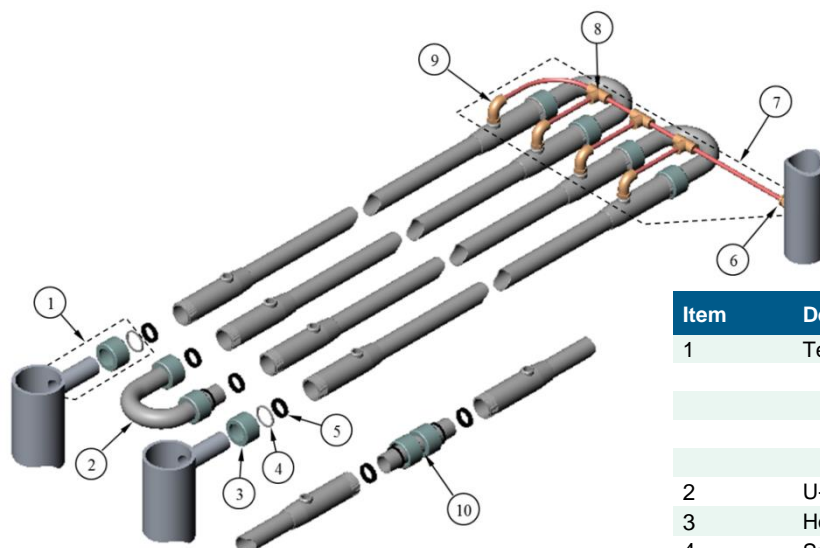

Item	Description	KPN
1	Terminator Kit Includes: Holding Nut, PVC (x2) Nipple, PVC (x2) Snap Ring, SS304 (x2)	0230020
2	U-Bend Assembly, CPVC	0020392
3	Holding Nut (PVC)	0020281
4	Snap Ring, SS304	0020310
5	Membrane Washer, Viton®	0020375
6	Permeate Straight Connector	0211800
7	Permeate Pass Kit (for 4 tubes) Includes: Adapter ¼ to ⅜ (x1) Permeate Tee Connector (x4) Permeate Elbow Connector (x4) PE Tubing	0211786
8	Permeate Tee Connector	0211803
9	Permeate Elbow Connector	0211804
10	Interconnector Kit, CPVC Includes: CPVC interconnector (x1) PVC Nut Holding (x2) Snap-Ring (x2)	0230091

The information contained in this publication is believed to be accurate and reliable, but is not to be construed as implying any warranty or guarantee of performance. We assume no responsibility, obligation or liability for results obtained or damages incurred through the application of the information contained herein. Refer to Standard Terms and Conditions of Sale and Performance Warranty documentation for additional information

Koch Separation Solutions, Inc. 850 Main Street, Wilmington, MA 01887
Main: +1-978-694-7000 • Fax: +1-978-657-5208 • Toll Free: +1-888-677-5624

For complete contact information and listing of our global locations, visit www.kochseparation.com

©2021 Koch Separation Solutions, Inc. All rights reserved worldwide. For related trademark information, visit www.kochseparation.com/legal.

04/21 Rev. 21-1